

CKC

V9

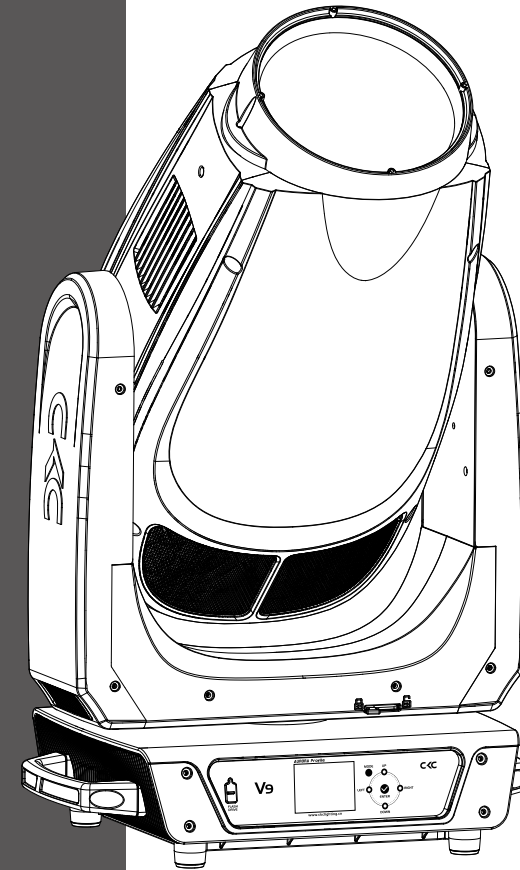

www.ckclighting.com

CKC LIGHTING CO.,LTD

Addr.:335 Nansha Avenue, Tung Chung Town,
Nansha District, Guangzhou City, China.
TEL: (020)3920 4506 FAX: (020)3920 4631
WEB: www.ckclighting.com



Before carrying out any installation, maintenance, or cleaning of the lighting fixtures, please confirm that the power has been cut off! Before using this fixture, please read this manual. Our company reserves the right to change product design and specifications without prior notice.

CONTENTS

1. Security Warning Information	1
2. Product Introduction	3
2.1 Exterior dimensions	3
2.2 Fixture packaging accessories	3
3. Main technical parameters of the equipment	3
4. Packaging and transportation	11
4.1 Disassemble packaging	11
4.2 Equipment installation	11
5. Installation Requirements Explanation	11
5.1 Clamp installation	11
5.2 Fixture installtion	13
5.3 Hanging Installation Diagram	13
6. Power and signal connection	14
6.1 Power and signal socket	14
6.2 Power Connect	14
6.3 Signal Connect	15
7. Control panel	15
7.1 Panel Introduction	15
7.2 System menu	16
8. DMX control channel table	18
9. Control circuit diagram	25
10. Regular maintenance	26
10.1 Cleaning and maintenance	26
10.2 Fault analysis and handling	26

★ Statement ★

- This manual contains important information on safe use and installation. Please read it carefully and follow the requirements for operation and installation. Please keep this manual properly;
- The equipment has good performance and complete packaging when it leaves the factory. The operator should strictly follow the warning items and operating instructions stated in the manual. Any malfunction or damage caused by misuse or neglect of the manual is not within the scope of our company's responsibility and warranty;
- The relevant information in this manual is for reference only. All lighting products are subject to the actual product. Any changes will not be notified separately, and our company reserves the right of final interpretation.

1. Security Warning Information



Attention !

Please read the safety requirements information in this section carefully before installing, powering on, operating, or repairing the lighting fixtures.



- This product is for professional use and is not suitable for other purposes;
- After receiving the lighting fixtures, please check if the packaging is complete and unpack to check if the equipment has been damaged due to transportation. If there is any damage caused by transportation, please do not use this lamp and contact local technicians or manufacturers as soon as possible;
- When transporting again, please use the original packaging materials;
- If there is obvious damage to the machine casing, it should be replaced in a timely manner;
- When hanging lamps, it is necessary to verify that the hanging equipment can withstand more than 6 times the weight of the lamp. After installation, it is necessary to verify that the lamp cover and installation buckle are secure and undamaged. At the same time, a safety rope should be used as an auxiliary safety for the lamp and fixed on the truss;
- The light source inside this luminaire should be replaced by the manufacturer, its service agent, or a similarly qualified person;
- If you have any other questions about how to safely operate the equipment, please contact our technical personnel or call our service hotline;
- This product has a protection level of IP30 and is suitable for indoor use;
- Avoid direct external strong light shining on the lens, which may cause the lens to focus and burn out internal components.



- Lighting fixtures should be kept clean and avoid prolonged use in overheated or dusty environments to prevent contact with chemical liquids;
- When using the product, attention should be paid to avoiding serious or fatal injuries caused by fire, heat, electrical shock, and ultraviolet radiation. Before powering on or installing, read the instruction manual first. Follow the safety precautions for operation and pay attention to the warning signs on the instructions and equipment;
- Only professionals are allowed to install, operate, and maintain lighting fixtures, and strictly follow the procedures stated in the operating instructions.



- The eyes cannot directly look at the luminous object;
- Do not connect this device to any dimmer;
- If visible damage occurs to the protective casing, lens, and display screen on the lighting fixture, it is considered as damage to the point of loss;
- Please do not place any filters or other items at the light outlet, and do not replace non original parts;
- The minimum safe illumination distance of the lamp is 3m.



- Before installation, please confirm that the power supply voltage used matches the voltage indicated on the light fixture. Each lighting fixture should be properly grounded and electrically installed according to relevant standards;
- Please disconnect the power before repairing or cleaning the equipment;
- During the operation of the lighting fixtures, touching the wires is prohibited to prevent electric shock;
- If the external soft cable or wire of this lamp is damaged, the wire should be replaced by the manufacturer, its agent, or a similarly qualified person to avoid danger;
- Avoid flammable liquids, water, or metal conductors from entering the interior of the lamp to prevent electric shock or fire. If any foreign objects enter the lamp, immediately cut off the power supply;
- When multiple lamps are operated in series, the signal lines can be connected in multiple ways, but the power supply must be connected separately.



- The lighting fixtures work normally at -20 °C to 45 °C . When replacing any components or accessories in the equipment, ensure that the power is disconnected to prevent electric shock and injury;
- The maximum surface temperature of the lamp during operation can reach 63 °C , please do not touch it with bare hands.



- The lighting fixtures must be installed in a sufficiently ventilated area, at least 0.5m away from adjacent surfaces, to ensure that no ventilation holes are blocked;
- Do not install the lighting fixtures directly on flammable objects;
- The minimum distance between all outer surfaces of the lamp and combustible materials is 0.5m.

2. Product Introduction

2.1 Exterior dimensions of lighting fixtures

446 × 331 × 788 mm

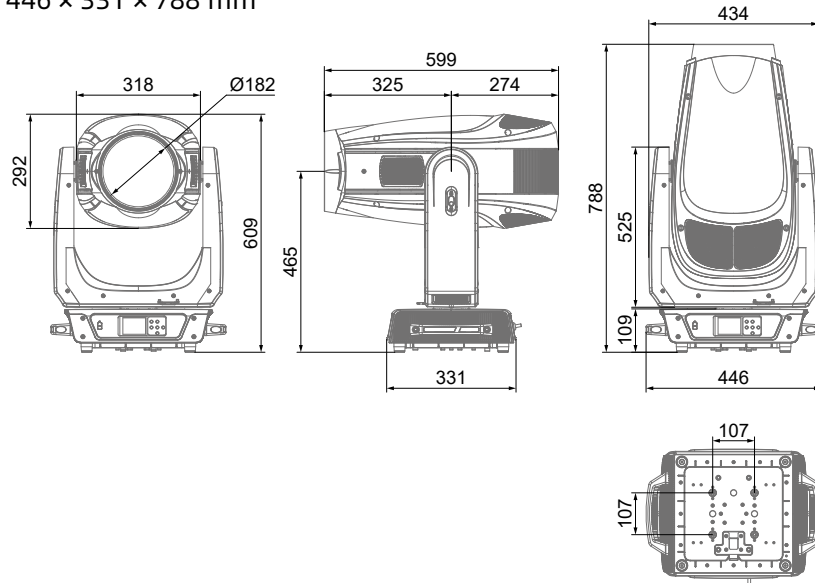

2.2 Packaging accessories

Name	QTY
Omega bracket	2 PCS
Clamp	2 PCS
Safety cable	1 PCS

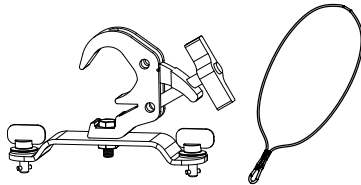

3. Main technical parameters of the equipment

Product execution standards: GB7000.1-2023,GB7000.217-2023, Q/YF-2017

● **Electrical parameter**

Rated input voltage: AC 100V-240V~ 50Hz/60Hz
 Rated power of the entire fixture: 1190 W
 Power factor: 0.999F
 Input Current: 5.91A 220V

● **Source lifespan**

>20000 hours

● **Color system**

CCT: 1800~10000K
 CRI: Ra/94
 R9/95

● **Gobo system**

Rotation gobo: 6+1
 Gobo outer diameter: 30 ±0.2 mm
 Internal diameter: 25mm
 Thickness: 1.1mm

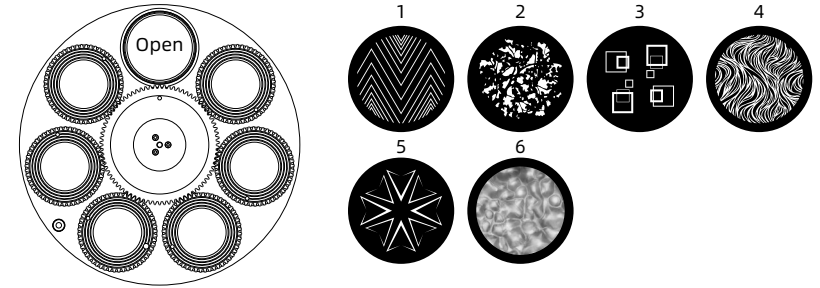

Fixed gobo: 7+1

Gobo outer diameter: 30 ±0.2 mm
 Internal diameter: 25mm
 Thickness: 1.1mm

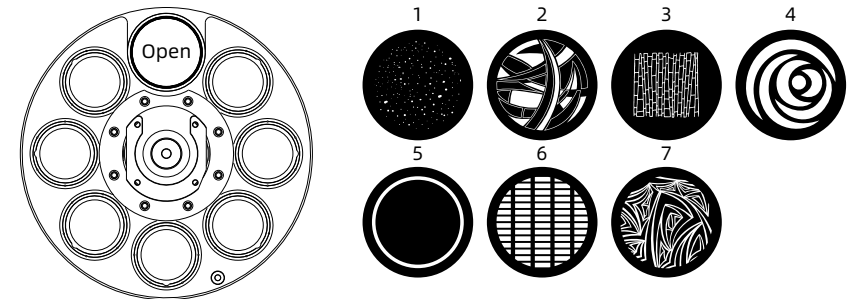

Gobo replace

1) Rotation gobo wheel

a). Remove the two screws at location **A**, unplug the power and signal adaptercables, and extract the Gobo component;

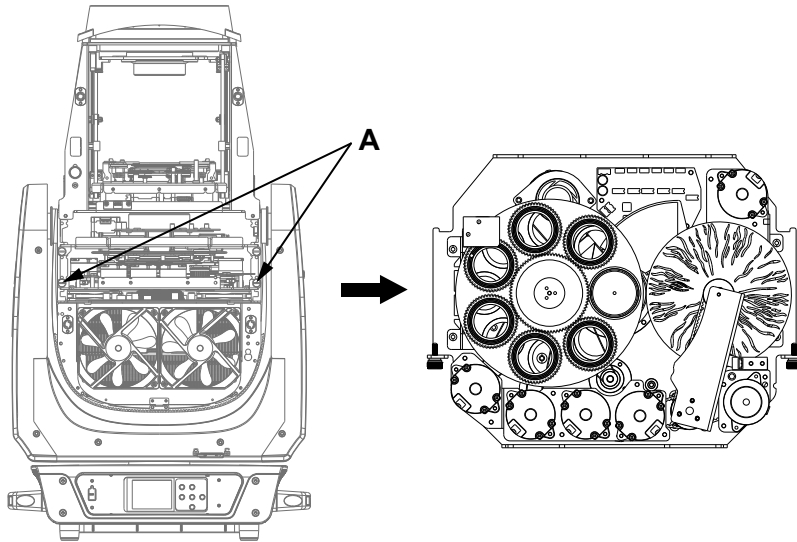

b). As shown in **B**, gently lift the driven wheel from the edge upwards from the front of the pattern plate and slowly pull it out to remove a single pattern seat;

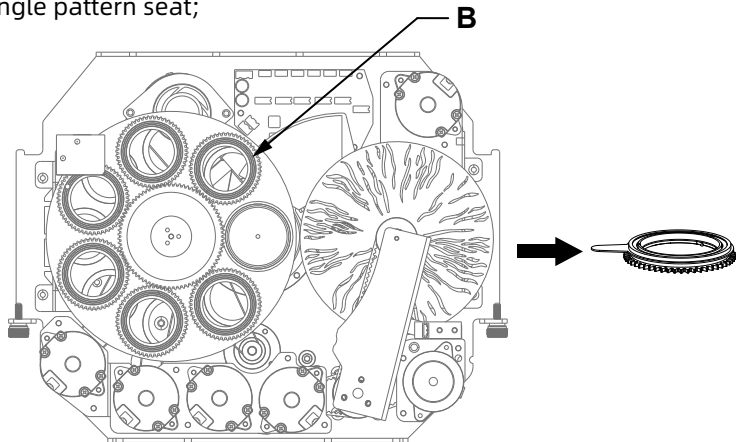

c). Use tweezers or other small grippers to remove the snap spring at point **C** (If the pattern piece is coated with glass glue for fixation, please use a professional cleaning agent to remove the glass glue before removing the snap spring to avoid damaging the gobo);

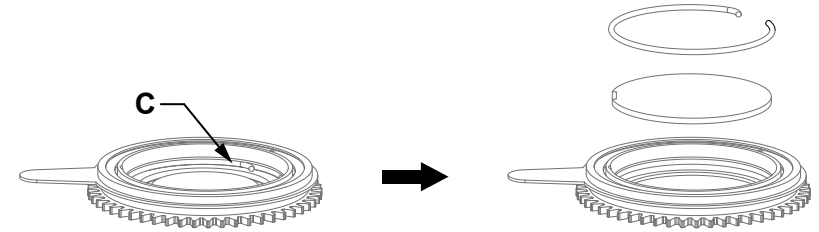

d). When assembling the gobo, avoid touching it directly with your hands. As shown in **D**, align the notch of the gobo with the recess of the driven wheel component (the coating surface of the gobo should face the light source);

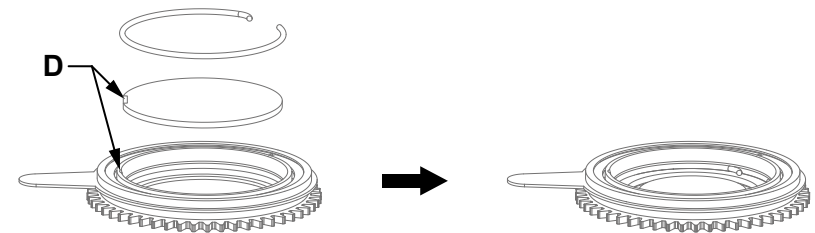

e). Insert the gobo holder into the drive wheel assembly, as shown in **E**, and reinstall the gobo holder in the order it was removed; The positioning point of the gobo holder should be aligned with the positioning point of the driving wheel; After installation, simply reinstall the gobo wheel component onto the light fixture.

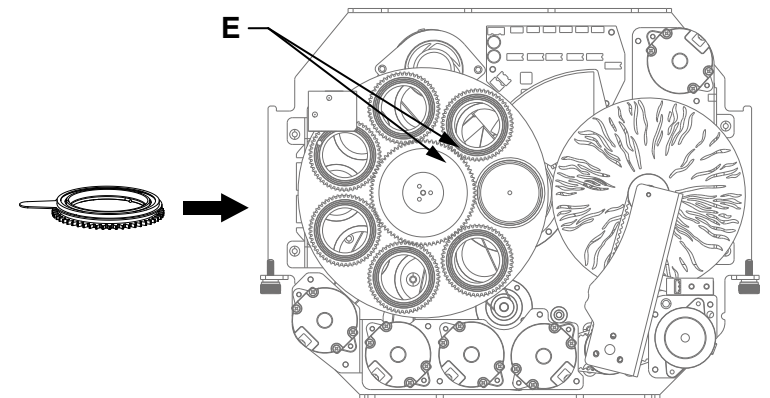

2) Fixing gobo wheel

a). Unscrew the two screws on the front **F** of the gobo wheel component and remove the magnetic sensing plate;

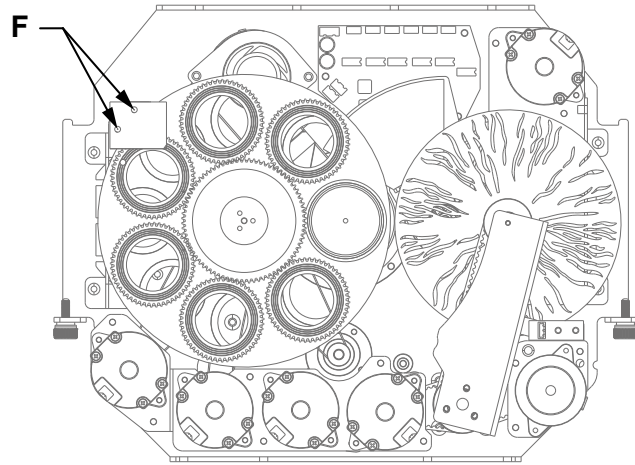

b). Reverse the components and loosen the 7 screws at **G** to loosen the belt; Unscrew the 4 screws at position **H** again to remove the gobo wheel component of the pattern disk;

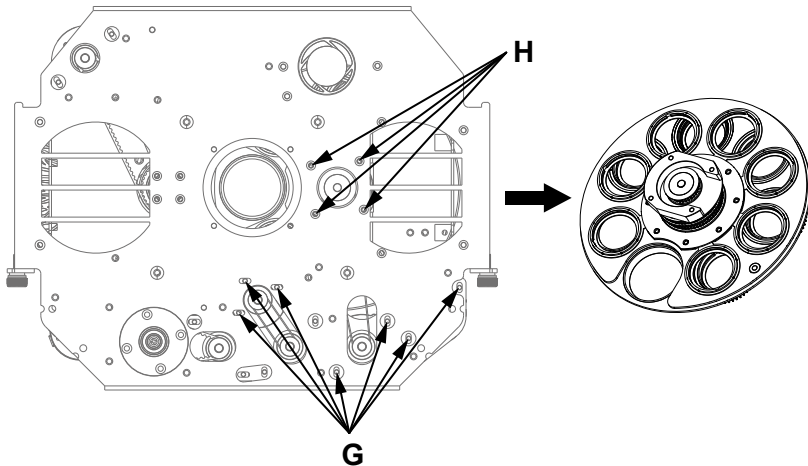

c). As shown in **I**, gently lift the gobo holder from the edge of the gobo wheel 2 and slowly pull it out to remove a single gobo holder;

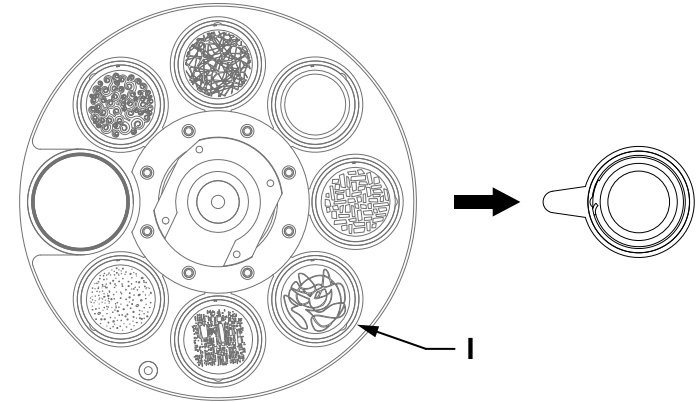

d). Use tweezers or other small grippers to remove the snap spring at point **J** (If the pattern piece is coated with glass glue for fixation, please use a professional cleaning agent to remove the glass glue before removing the snap spring to avoid damaging the gobo);

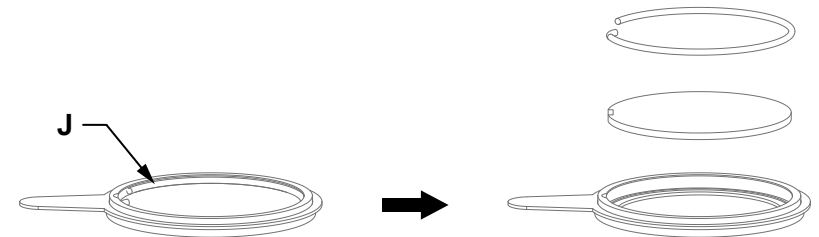

e). When assembling the gobo, avoid touching it directly with your hands. As shown in **K**, align the notch of the gobo with the recess of the driven wheel component (the coating surface of the gobo should face the light source);

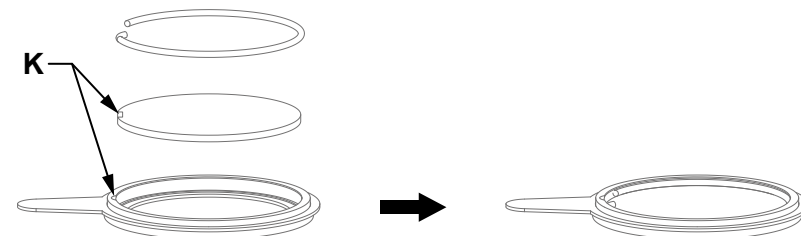

f). Insert the gobo wheel into the drive wheel assembly, as shown in L, and reinstall the gobo holder in the order it was removed;

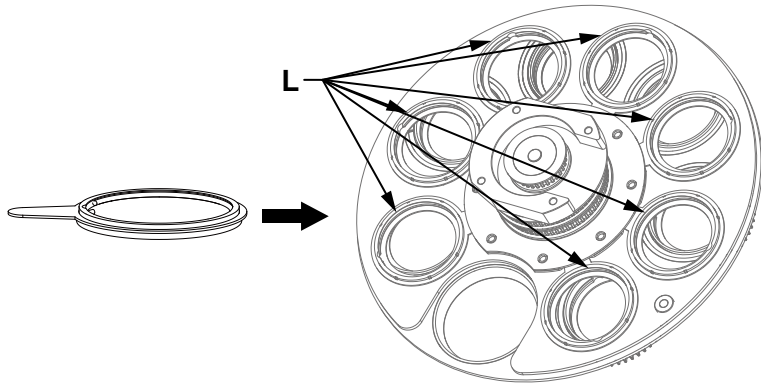

g). After installation, simply reinstall the gobo wheel component onto the light fixture.

● **Framing system**

4 gratings achieve fast and smooth cutting, and the cutting direction and angle of each grating can be controlled separately. The single grating can achieve complete light closure, and the entire frame module can rotate ±60°

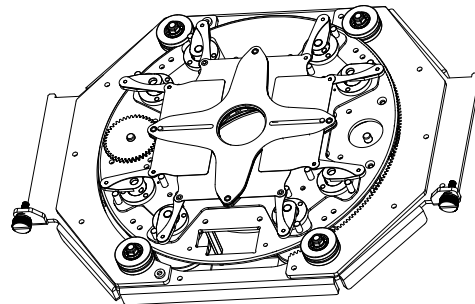

● **Animation**

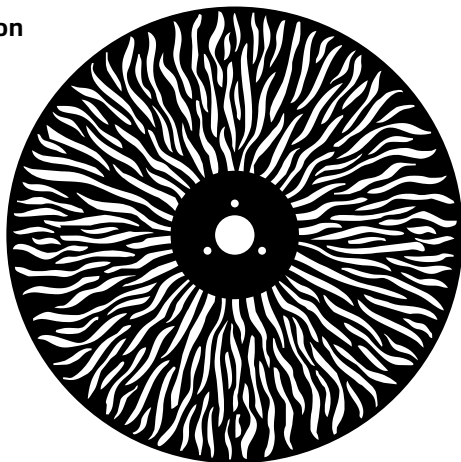

● **Prism system**

4 prism+ 6 linear

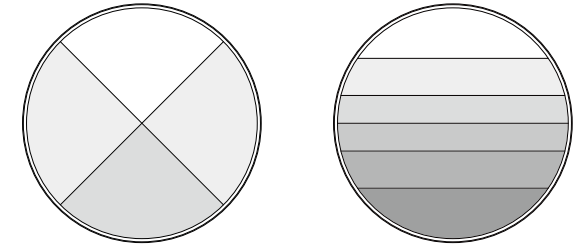

● **Pan/Tilt**

Pan scan:
540° or 630° 8-bit/16bit recision scanning
Tilt scan:
270° 8-bit/16bit precision scanning

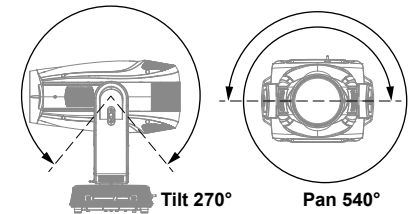

● **Optical system**

Beam angel: 6 ~ 52°
Source: 800W RGBAL LED
Output luminous flux: 21000 Lm

● **Control and programming**

Control channel: 37CH/39CH/57CH
Protocol: DMX512, RDM
Data connect: 3 or 5 pin signal in/out

● **Illumination draw**

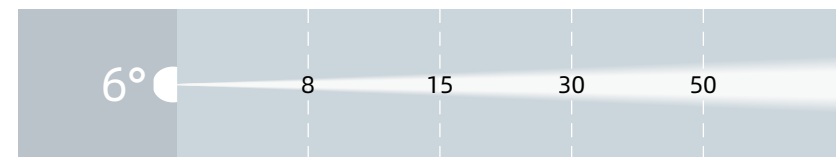

Lux	19200	8770	1372	494
Distance(m)	0.84	1.57	3.14	5.24

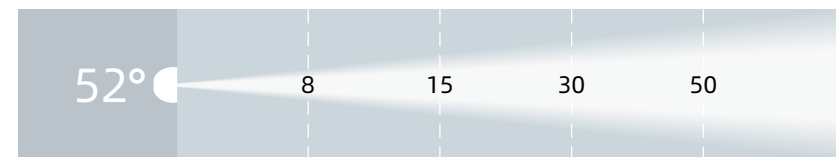

Lux	837	409	50	
Distance(m)	7.80	14.63	29.26	

● **Other effect function**

Fast electronic strobe: 1~25Hz
LED refresh frequency: 1200Hz-25KHz

Frost: Light frost+heavy frost
Iris

● **Other features and functions**

Weight: 41.4 KG

4. Packaging and transportation

4.1 Disassemble packaging

 Notice: After receiving the fixture, please unpack and check for any damage caused by transportation. If there is any damage caused by transportation, please do not use this fixture and contact the local technical personnel or manufacturer as soon as possible.

4.2 Equipment packaging

- 1). Disconnect the power supply before packaging the lighting fixtures to allow them to cool completely;
- 2). Flight cases can only be stacked in two layers and are not allowed to be reversed.

5. Installation Requirements Explanation

5.1 Clamp install

The lighting fixtures can be installed on the stage or on any direction of the truss, and the clamp can be quickly and easily locked onto the truss.

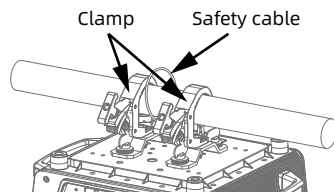



Warning !
The lighting fixtures are divided into two versions: integrated light hook and normal. When using the integrated light hook version, the clamp is broken up and locked onto the truss. The normal version must use 2 clamps to secure the device and fasten it with a 1/4 rotation. Regardless of the version, one safety rope must be added and connected to the base hole, but be careful not to connect it to the handling handle.

Integrated clamp installation

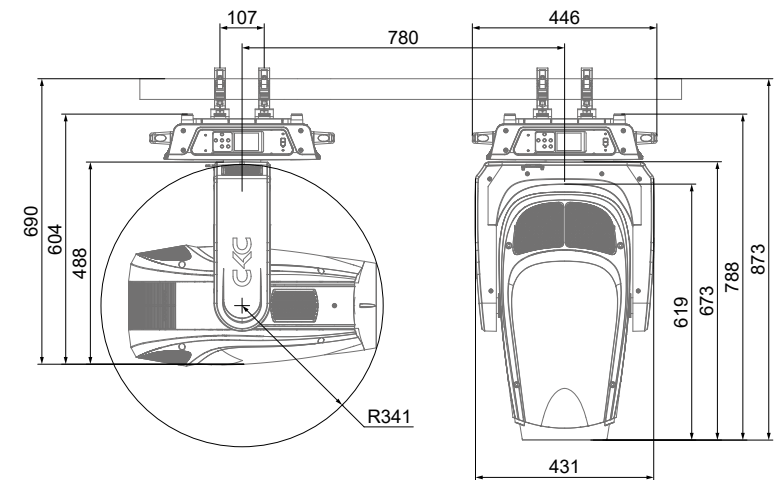
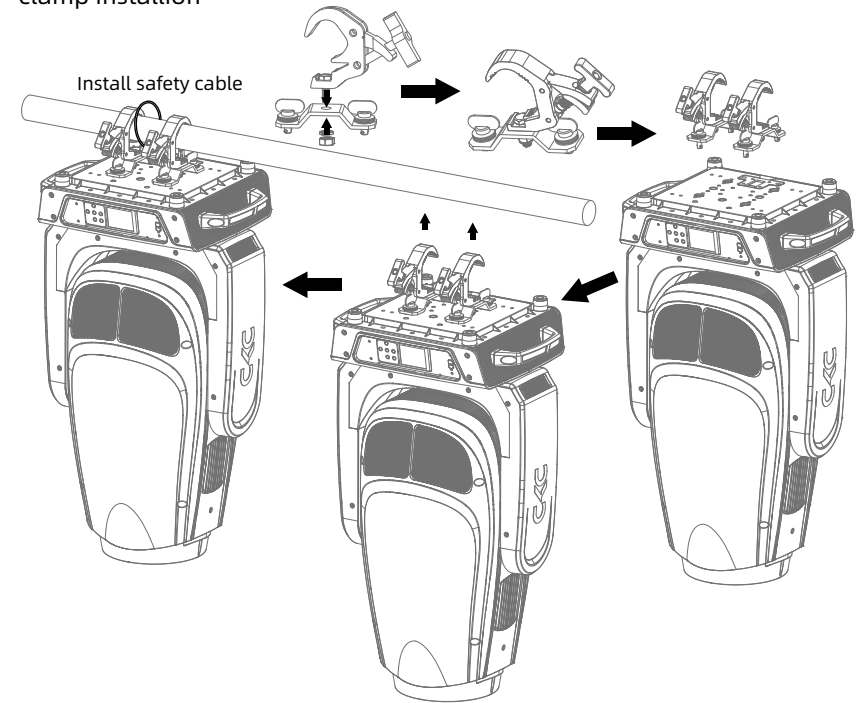

5.2 Equipment installation

- 1). Before installation, it is necessary to verify that the lamp hook and safety rope are not damaged, and that the installation object can withstand 6 times the total weight of the lamp and cable accessories;
- 2). Install the quick lock clamp on the base of the lamp body. Insert the clamp horizontally into the mounting hole of the base, rotate it clockwise 1/4 turn to lock it, and install the second clamp using the same method (the shape of the clamp should be based on the actual product).

5.3 Hanging Installation Diagram

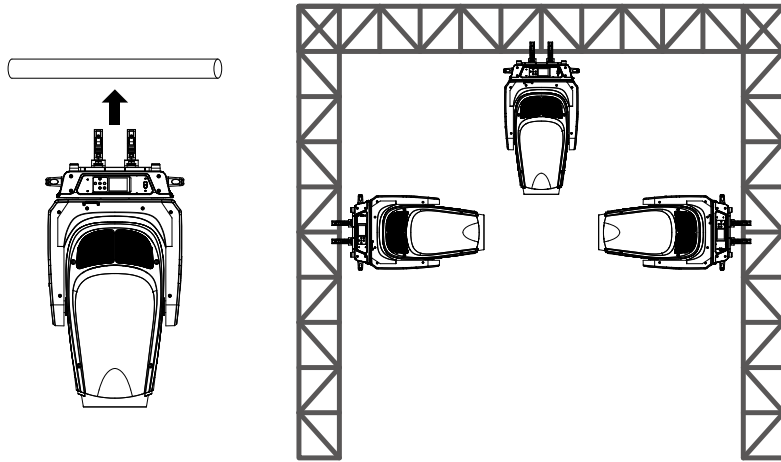

⚠ Reminder: External beam source may damage internal lighting fixtures

External beams from direct sunlight, lighting fixtures, and lasers that are directly focused onto the casing or penetrate the lens to illuminate the interior of the fixture may cause damage to the components. This is a common issue with all lighting fixtures and does not occur alone with KCC products. Although there is no way to completely prevent this problem from occurring, following the following guidelines can prevent potential damage.

When unpacking, installing, using, and stopping the operation of the lighting fixtures, please do not expose the transparency of the fixtures the mirror is exposed to direct sunlight, other lighting fixtures, or laser beams, Do not directly focus the beam of this device onto another lighting fixture.

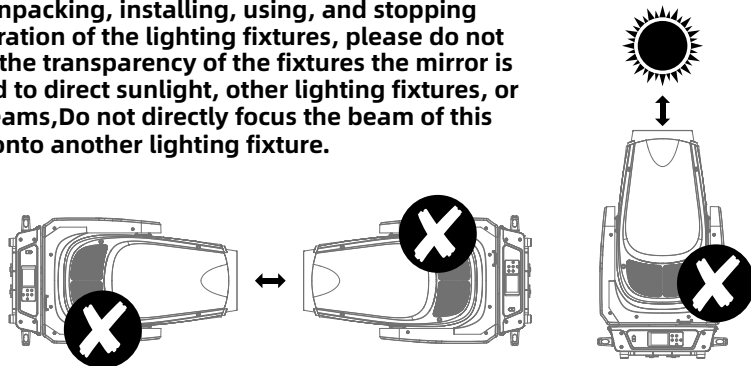

6. Power、 Signal connect

6.1 Power and signal socket

- 1.Fuse holder
- 2.Power input
- 3.DMX input
- 4.DMX input
- 5.DMX output
- 6.DMX output

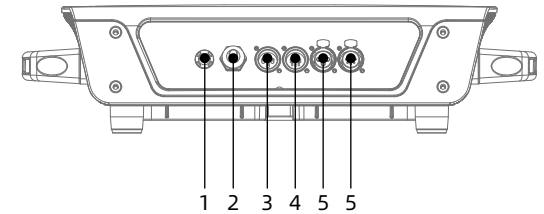

6.2 Power connect

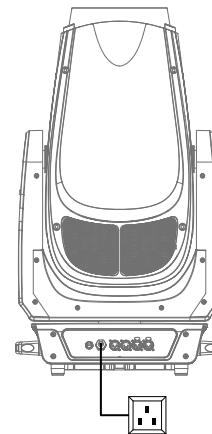

Connection method:

L(live wire) - brown wire

E(Ground wire) - yellow/green dual color line

N(Zero Line) - Blue Line

When connecting the power supply, please note that the voltage and frequency of the power supply must match the voltage and frequency marked on the light fixture. When multiple fixtures are used simultaneously, it is recommended to connect the power supply of each fixture separately, so that each fixture can be individually controlled for power on/off.

⚠ Attention: When connecting the power supply, the ground wire (yellow/green dual color wire) must be safely grounded and comply with all relevant electrical installation standards.

This product uses Powercon In/Out to connect power cords. Due to power limitations, a 2-square 220V power cord can carry up to 1 products.

Warning !



- Do not connect too many fixtures or overload a single power cord;
- Do not use power cords with damaged insulation layers, and do not place power cords on other wires;
- When the fixture is not in use or cleaned, please unplug the power cord; Do not forcefully unplug or drag the power cord directly.

6.3 Signal connect

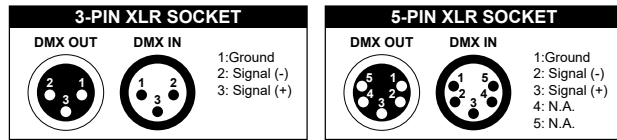

The lighting fixtures are equipped with standard DMX XLR input and output sockets. Please use DMX512 shielded twisted pair signal cables or Category 3/5 or above network twisted pair cables for connection. The typical connection distance for DMX signal lines is 150 meters. When transmitting signals over long distances, a DMX512 signal amplifier must be added.

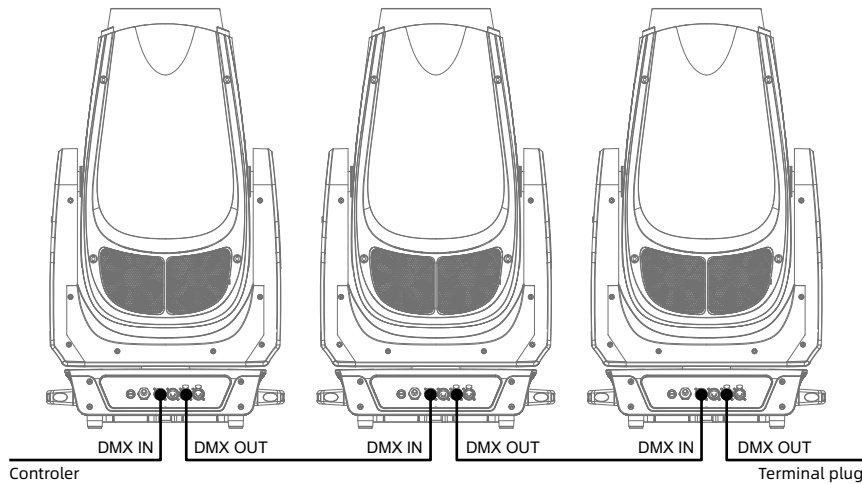

Connect a shielded twisted pair signal cable from the DMX output port of the controller to the DMX input port of the first device, and from the DMX output port of the first device to the DMX input port of the second device, and so on, until all the lamps are connected. Then install a terminal plug on the last 3 pin socket of each connected lamp output. (Weld a 4/1W, 120 Ω resistor between the 2 and 3 pins of a 3 or 5 core pin XLR plug).

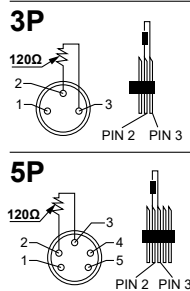

7. Control panel

7.1 Panel Introduction

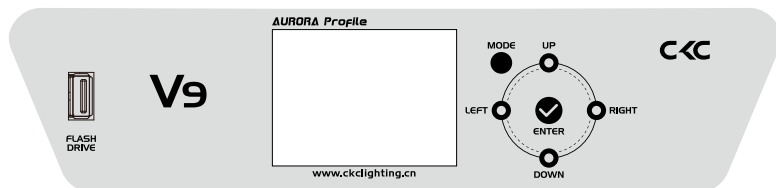

- Adopting a 2.8 "LCD display screen, the operation panel is equipped with a rechargeable battery, which can enter the menu to set address codes and make other settings without powering on;
- Press the MODE key to view or modify the lighting function settings, and press the UP, DOWN, LEFT, and RIGHT keys to select the function menu;
- Press the ENTER key to confirm your selected function menu, which will take you to the corresponding sub menu in the menu. Each menu item represents a specific function of the lighting fixture (as shown in the table below);
- Press the ENTER key to save your modifications or enter a submenu, and press the UP or DOWN key to modify values (increase or decrease values); Press the MODE key to return to the previous menu or exit.
- Press the MODE key to return to the previous menu or exit.

7.2. System menu

Note: The gray color block is the default setting value

Software Update Please Wait... CKC Fixture Type Check V9 Motor Reset			
SET	Dmx Presets	A001~AXXX	
	User Mode	Standard (39CH) Extend (57CH) CMY MODE (37CH)	
Status	No DMX Mode	Black/ Hold/ Auto	
	P.Reverse	ON/OFF	
Dim Mode	T.Reverse	ON/OFF	
	Pan Degree	630/540	
Temp. C/F	Feedback	ON/OFF	
	Move.Speed	Speed 1~ 4	
Function	Hibernation	OFF, 01M~99M, 15M	
	Dim Mode	Standard Stage TV Architectural Theatre	
Dim Curve	Temp. C/F	Celsius Fahrenheit	
	Dim Curve	Linear Square Inv-Square S-Curve	
Frequency	1200Hz/3600Hz/5000Hz/10KHz/15KHz/20KHz/25KHz		
Power Mode	Normal/ Theatre		

CTO Mode	Mode1/Mode2		
Fan Set	Head Fan	Auto High Low	
	Base Fan	Auto High Low	
LCD.Set	Backlight Flip Display Key Lock DispFlash Language	01~60m OFF/ON OFF/ON OFF/ON English	
Disp.Set	Channel Value Slave Set Auto.Prog	PAN..... Slave1,Slave2,Slave3 Master / Alone	
DFSE	OFF/ON		
USB Update	OFF/ON		
Test	Reset.M	All Pan&Tilt Other	
	Test.Chan	PAN	
	Panel.Ctrl.	PAN =XXX :	
	Calibrate	-Password 050- PAN :	
Info	Time.Info	Current (Hours) Total Time (Hours) Last Time (Hours) Timer PIN (Password=50) Clear Last (ON/OFF)	
	Temp. Info	Base Temp. Head Temp.	
	Fan Speed	Base Fan1:xxxx RPM Base Fan2: xxxx RPM Cool Fan1: xxxx RPM	
	Error. Info	Pan,Tilt.....	
	Model. Info	V9	
	Software.V	1U V 1.0.X 2U V 1.0.X 3U V 1.0.X 4U V 1.0.X 5U V 1.0.X 6U V 1.0.X	

8. DMX channel table:

Value				Function
St	Ex	CMY		
1	1	1	0-255	PAN Movement 8bit Pan Movement By 630/540
2	2	2	0-255	Pan Fine 16bit Fine control of Pan movement
3	3	3	0-255	TILT Movement 8bit Tilt Movement
4	4	4	0-255	Tilt Fine 16bit Fine control of Tilt movement
5	5	5	0-255	Dimmer (intensity) Intensity 0 to 100%
6	6	6	0-255	Dimmer Fine Intensity 0 to 100%
7	7	7	0-255	Shutter, strobe
				0-31 No function (shutter closed)
				32-63 No action,shutter open
				64-95 Slow to fast strobe
				96-127 No action,shutter open
				128-159 Slow to fast pulse effect
				160-191 No action,shutter open
192-223 Slow to fast random strobe				
224-255 No action,shutter open				
8	8		0-255	Red: Intensity 0 to 100%
	9		0-255	Red Fine: Intensity 0 to 100%
9	10		0-255	Green: Intensity 0 to 100%
	11		0-255	Green Fine: Intensity 0 to 100%
10	12		0-255	Blue: Intensity 0 to 100%
	13		0-255	Blue Fine: Intensity 0 to 100%
11	14		0-255	Amber: Intensity 0 to 100%
	15		0-255	Amber Fine: Intensity 0 to 100%

12	16		0-255	Lime: Intensity 0 to 100%
	17		0-255	Lime Fine: Intensity 0 to 100%
		8	0-255	CYAN: Intensity 0 to 100%
		9	0-255	Magenta: Intensity 0 to 100%
		10	0-255	YELLOW: Intensity 0 to 100%
13	18	11		Color Macros:
			0	No function
			1-70	Color Macros(see separate sheet)
			71-255	open
14	19	12		CTO Mode1:
			0-17	No function
			18 -100	1800K - 10000K(1DMX → 100K)
			101-120	3200K
			121-140	4500K
			141-160	5600K
			161-180	6500K
			181-200	7500K
			201-220	8000K
			221-255	No function
14	19	12	0-255	CTO Mode2: 6500K-1800K
15	20	13		Green Shift:
			0	No function
			1-127	Full Minus Green to Neutral
			128	Neutral White
			129-255	Neutral to Full Plus Green
16	21	14	0-255	Colour Yellow
	22		0-255	Colour Fine Yellow Fine
				Rotating gobos, cont. rotation
			0~5	Open/Hole
			6~20	Gobo 1
			21~35	Gobo 2
			36~50	Gobo 3
			51~65	Gobo 4

17	23	15	66~80	Gobo 5
			81~95	Gobo 6
			96~110	Gobo 1 shake, from slow to fast
			111~125	Gobo 2 shake, from slow to fast
			126~140	Gobo 3 shake, from slow to fast
			141~155	Gobo 4 shake, from slow to fast
			156~170	Gobo 5 shake, from slow to fast
			171~185	Gobo 6 shake, from slow to fast
			186- 192	Open
			193~223	Gobo Wheel rot. Slow -> Fast, CW
			224~224	Stop
			225~255	Gobo Wheel rot. Fast -> Slow, CCW
18	24	16		Rotating gobo index, rotating gobo rotation
			000-128	GoboRot indexing
			129-191	Gobo Wheel rot. Slow -> Fast, CW
			192-192	Stop
			193-255	Gobo Wheel rot. Fast -> Slow, CCW
19	25	17	000-255	Rotating gobo index Fine
20	26	18		Fixed Gobos Wheel
			0~5	Open
			6~18	FixedGobo1
			19~31	FixedGobo 2
			32~44	FixedGobo 3
			45~57	FixedGobo 4
			58~70	FixedGobo 5
			71~83	FixedGobo 6
			84~96	FixedGobo 7
			97-109	FixedGobo 1 shake,from slow to fast
			110~122	FixedGobo 2 shake,from slow to fast
			123~135	FixedGobo 3 shake,from slow to fast
			136~148	FixedGobo 4 shake,from slow to fast
			149~161	FixedGobo 5 shake,from slow to fast
			162~174	FixedGobo 6 shake,from slow to fast
			175~187	FixedGobo 7 shake,from slow to fast
			188~192	Open
193~223	Gobo Wheel rot. Slow -> Fast, CW			
			224~224	Stop
			225~255	Gobo Wheel rot. Fast -> Slow, CCW
21	27	19	0-255	Zoom Zoom from min. to max.beam angle

	28		0-255	Zoom-fine Zoom Fine
22	29	20	0-255	Focus Continuous adjustment from far to near
	30		0-255	Focus-fine Focus Fine
23	31	21		Iris:
			0-191	Iris:0 - 100%(Linear)
			192-236	Pulse opening effect from slow to fast
			237-245	Pulse closing effect from slow to fast
			246-255	Iris rotation slow to fast
	32		0-255	Iris-fine Fine iris movement
24	33	22		Prism:
			0-5	Open
			6-130	Prism 1 (6 liner Prism)
			131-255	Prism 2 (4 Facet Prism)
25	34	23		Prism rotation:
			000-005	Prism indexing
			006-128	Prism Position 0 ... 540°
			129-191	Prism Rotation, Slow -> Fast, CW
			192-192	Stop
			193-255	Prism Rotation, Fast -> Slow, CCW
26	35	24	0-255	Frost: Frost:0 - 100%(Linear)
27	36	25	0-255	Frost2: Frost:0 - 100%(Linear)
28	37	26		Animation1:
			0-5	open
			6-128	Wheel Position 0 ... 540°
			129-191	Wheel rot. Slow -> Fast, CW
			192-192	Wheel rot. Stop
			193-255	Wheel rot. Fast -> Slow, CCW
29	38	27	0-255	Framing shutters module rotation Rotation from right 0° to 120°
	39		0-255	Framing shutters module rotation Fine(16Bit) Fine Rotation from right 0° to 120°
30	40	28	0-255	Blade 1A Movement from Outward to Inward
	41		0-255	Blade 1A Fine Movement from Outward to Inward

31	42	29	0-255	Blade 1B Movement from Outward to Inward
	43		0-255	Blade 1B Fine Movement from Outward to Inward
32	44	30	0-255	Blade 2A Movement from Outward to Inward
	45		0-255	Blade 2A Fine Movement from Outward to Inward
33	46	31	0-255	Blade 2B Movement from Outward to Inward
	47		0-255	Blade 2B Fine Movement from Outward to Inward
34	48	32	0-255	Blade 3A Movement from Outward to Inward
	49		0-255	Blade 3A Fine Movement from Outward to Inward
35	50	33	0-255	Blade 3B Movement from Outward to Inward
	51		0-255	Blade 3B Fine Movement from Outward to Inward
36	52	34	0-255	Blade 4A Movement from Outward to Inward
	53		0-255	Blade 4A Fine Movement from Outward to Inward
37	54	35	0-255	Blade 4B Movement from Outward to Inward
	55		0-255	Blade 4B Fine Movement from Outward to Inward
38	56	36		Dim Modes
			0-20	Standard
			21-40	Stage
			41-60	TV
			61-80	Architectural
			81-100	Theater
			101-255	Default to Unit Setting
				Lamp on/off, reset, internal programs
	0-5	No function		
	6-10	Display OFF(Hold 3s)		
	11-15	Display ON(Hold 3s)		
	16-20	Invert Pan on (Hold 3s)		
	21-25	Invert Pan off (Hold 5s)		

39	57	37	26-30	Invert Tilt on (Hold 3s)
			31-35	Invert Tilt off (Hold 5s)
			36-39	Fan Auto (Default)
			40-42	Fan Silent (Hold 3s)
			43-45	Fan High(Hold 3s)
			46-50	Linear Dimmer Curve (hold 3s)
			51-55	Square Dimmer Curve (hold 3s)
			56-60	Inv-Square Dimmer Curve (hold 3s)
			61-65	S - Dimmer Curve (hold 3s)
			66-70	Led Freq. 1200 Hz (hold 3s)
			71-75	Led Freq. 3600 Hz (hold 3s)
			76-80	Led Freq. 5000 Hz (hold 3s)
			81-85	Led Freq. 10.000 Hz (hold 3s)
			86-90	Led Freq. 15.000 Hz (hold 3s)
			91-95	Led Freq. 20.000 Hz (hold 3s)
			96-100	Led Freq. 25.000 Hz (hold 3s)
			101-105	All motor reset(hold 3s)
			106-110	P/T motor reset(hold 3s)
			111-115	Other motor reset(hold 3s)
			116-120	Power Mode Normal
			121-125	Power Mode Theatre
			126-130	DTW ON
			131-135	DTW OFF
			136-140	CTO Mode1 (Default)
			141-145	CTO Mode2
146-255	No function			

13	49	Medium purple	64	203	Quarter c.T. Blue
14	68	Sky blue	65	204	Full c.T. Orange
15	71	Tokyo blue	66	205	Half c.T. Orange
16	79	Just blue	67	206	Quarter c.T. Orange
17	88	Lime green	68	248	Half miuns green
18	90	Dark yellow green	69	285	Three quarter c.T.Orange
19	100	Spring yellow	70	793	Vanity fair
20	101	Yellow	71		Pale blue
21	102	Light amber	72		Dark salmon
22	103	Straw	73		Light amber
23	104	Deep amber	74		Fire
24	105	Orange	75		Dark amber
25	106	Primary red	76		Lavender tint
26	111	Dark pink	77		Pale green
27	113	Magenta	78		Forest green
28	115	Peacock blue	79		Ct straw
29	116	Medium blue-green	80		1/2 Ct straw
30	117	Steel blue	81		Sally green1
31	118	Light blue	82		Sally green2
32	119	Dark blue	83		Sally green3
33	120	Deep blue	84		Rust
34	122	Fern green	85		Aurora borealis green
35	128	Bright pink	86		Medium yellow
36	131	Marine blue	87		Deep golden amber
37	132	Medium blue	88		Light pink
38	134	Golden amber	89		Medium bastar
39	135	Deep golden amber	90		Magenta
40	136	Pale lavender	91		Dark blue
41	137	Special lavendr	92		Rose purple
42	138	Pale green	93		Deep amber
43	139	Primary green	94		Follies pink
44	141	Bright blue	95		3/4 Blue
45	147	Apricot	96		Plum
46	148	Bright rose	97		Lo sodium1
47	152	Pale gold	98		Lo sodium2
48	154	Pale rose	99		Lo sodium3
49	157	Pink	100		Elysian blue
50	158	Deep orange	101		Mauve
51	162	Bastard amber	102		Sunset red

Virtual Swatch Book

Value	Filter Number	Name	Value	Filter Number	Name
1	4	Medium bastard amber	52	164	Flame red
2	10	Medium yellow	53	165	Daylight blue
3	15	Deep straw	54	169	Lilac tint
4	19	Fire	55	170	Deep lavender
5	21	Gold amber	56	172	Lagoon blue
6	22	Dark amber	57	179	Loving amber
7	24	Scarlet	58	180	Dark lavender
8	26	Bright red	59	181	Congo blue
9	27	Medium red	60	197	Alice blue
10	36	Medium pink	61	200	Double c.T. Blue
11	46	Dark magenta	62	201	Full c.T. Blue
12	48	Rose purple	63	202	Half c.T. Blue

9. Control circuit diagram

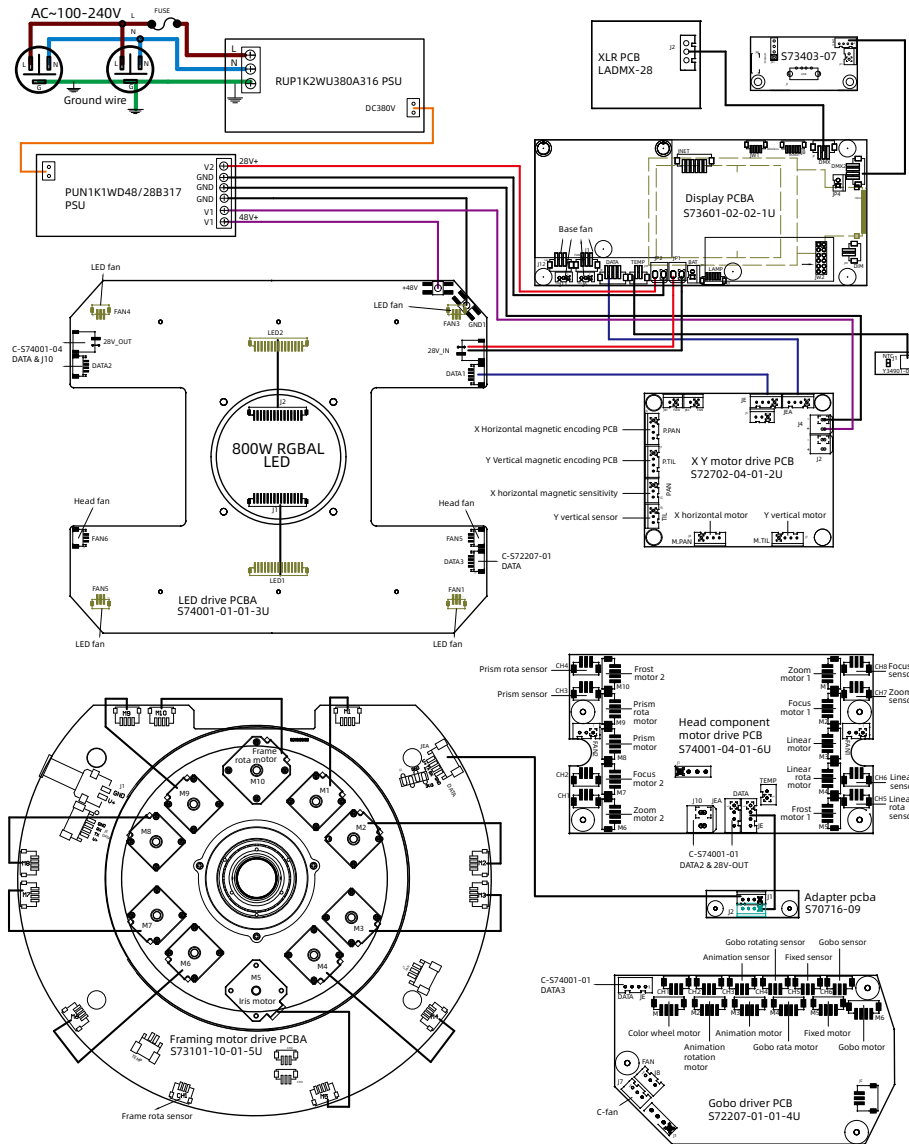

10. Regular maintenance

10.1 Cleaning and maintenance

Lighting fixtures require daily cleaning and maintenance, and their service life largely depends on the operating environment and standards. If you have any questions, please consult our technical engineers for advice. Maintenance and repair work not included in this book should be entrusted to our qualified technical engineers.

Attention! Damage caused by dust, e-liquid, or other reasons, as well as abnormal use, is not covered by the warranty.



Warning ! Before opening any lid, disconnect the power supply. Cleaning optical components requires gentle wiping as the coating surface is prone to scratching. Do not use damaging liquids or hard objects, as they may damage the plastic or coating surface.

- When the lens is cracked or otherwise damaged, it should be replaced in a timely manner;
- When the brightness significantly decreases, the LED may have reached its expiration date and should be replaced in a timely manner;
- When the fixture cannot start, please check if the fixture power fuse is blown. If it is blown, a fuse of the same specification must be used for installation;
- The fixture is equipped with a temperature protection device. When the temperature is too high, the protection device will automatically reduce power.
- When this situation occurs, please check whether the fan is running normally, whether the fan and fan mesh are clogged with dust, identify the fault and repair it before starting the fixture. Please note that only qualified technicians are allowed to carry out maintenance work;
- To maintain smooth movement of the focusing lens, it is recommended to lubricate the guide rail of the focusing lens every three months. Excellent and high-temperature resistant lubricating grease should be used, and excessive grease should not be used as it can easily dirty adjacent components.

10.2 Fault analysis and handling

Fault description	Analysis	Processing method
No action after power on	Check if the power switch is turned on	Turn on
	Check if the fuse is blown	Replace
	Check if the output of PSU is normal	Detecting voltage
	Check if poor contact in the internal circuit	Reconnect

Uncontrolled lighting fixtures	Check if the DMX signal cable is connected correctly (If there is no signal, the display screen will flash)	Reconnect or replace
	Check if the address code is correct and if the DMX mode of the lighting fixture matches the settings	Reconfirm
	The main control PCB is damaged	Replace
Not bright	LED aging or damage	Replace
	Power PCB malfunction	Check/ Replace
	Loose or poor contact of the circuit	Reconnect
	PSU malfunction	Replace
Automatically turn off or dim the lights	LED aging	Replace
	Damaged cooling fan or abnormal wind speed	Replace
	Check the power output of the fan	Check/ Replace
	The temperature control switch is damaged	Replace
Gobo wheel misalignment or abnormal control	Poor contact of motor wire	Reconnect
	Corresponding motor drive board malfunction	Refixed
	Misalignment or magnetic damage between the magnetic tube and the positioning magnet	Adjust/Replace
	Motor malfunction	Replace
Weak light efficiency and uneven light spot	LED aging	Replace
	LED not centered with the lens	Adjust LED
	The optical mirror has accumulated dust or stains	Clean
	The optical mirror is damaged	Replace
Impure color	Weakening of light efficiency	Replace led PCB
	The color filter has accumulated dust or stains	Clean
	The color filter has been demolded or damaged	Replace

Gobo is unclear	The optical mirror has accumulated dust or stains	Clean
	The optical mirror is damaged	Replace
Head or base fan stops rotating	Check if the fan leads are installed properly or disconnected	Re connect
	Check if the fan is damaged	Replace
	Check if there are any other interfering objects within the operating range of the fan	Adjust
 Attention! The above analysis is for abnormal reference only. Non professionals are not allowed to disassemble and repair the machine		

