

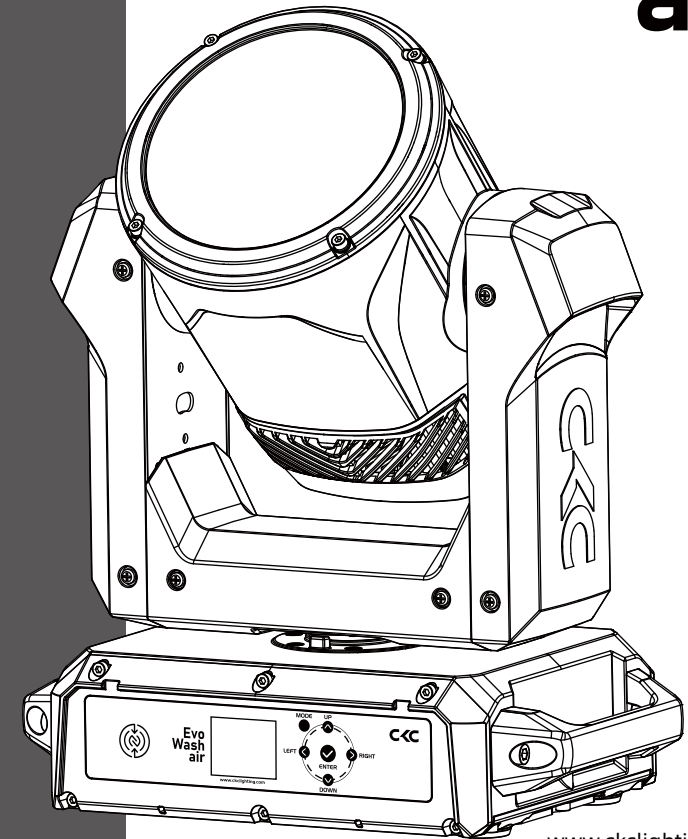

EvoWash air



www.ckclighting.com

CKC LIGHTING CO.,LTD

Addr.:335 Nansha Avenue, Tung Chung Town,
Nansha District, Guangzhou City, China.
TEL: (020)3920 4506 FAX: (020)3920 4631
WEB: www.ckclighting.com



Before carrying out any installation, maintenance, or cleaning of the lighting fixtures, please confirm that the power has been cut off! Before using this fixture, please read this manual. Our company reserves the right to change product design and specifications without prior notice.

CONTENTS

| | |
|--|-----------|
| 1. Security Warning Information | 1 |
| 2. Product Introduction | 3 |
| 2.1 Dimensional drawings | 3 |
| 2.2 Fixture packaging accessories | 3 |
| 3. Main technical parameters of the equipment | 3 |
| 4. Packaging and transportation | 4 |
| 4.1 Disassemble packaging | 4 |
| 4.2 Equipment installation | 5 |
| 5. Installation Requirements Explanation | 5 |
| 5.1 Clamp installation | 5 |
| 5.2 Fixture installtion | 6 |
| 5.3 Hanging Installation Diagram | 6 |
| 6. Power and signal connection | 7 |
| 6.1 Power and signal socket | 7 |
| 6.2 Power Connect | 7 |
| 6.3 Signal Connect | 8 |
| 7. Control panel | 9 |
| 7.1 Panel Introduction | 9 |
| 7.2 System menu | 9 |
| 8. DMX control channel table | 12 |
| 9. Control circuit diagram | 18 |
| 10. Regular maintenance | 19 |
| 10.1 Cleaning and maintenance | 19 |
| 10.2 Fault analysis and handling | 19 |

★ Statement ★

- This manual contains important information on safe use and installation. Please read it carefully and follow the requirements for operation and installation. Please keep this manual properly;
- The equipment has good performance and complete packaging when it leaves the factory. The operator should strictly follow the warning items and operating instructions stated in the manual. Any malfunction or damage caused by misuse or neglect of the manual is not within the scope of our company's responsibility and warranty;
- The relevant information in this manual is for reference only. All lighting products are subject to the actual product. Any changes will not be notified separately, and our company reserves the right of final interpretation.

1. Security Warning Information



Attention !

Please read the safety requirements information in this section carefully before installing, powering on, operating, or repairing the lighting fixtures.



- This product is for professional use and is not suitable for other purposes;
- After receiving the lighting fixtures, please check if the packaging is complete and unpack to check if the equipment has been damaged due to transportation. If there is any damage caused by transportation, please do not use this lamp and contact local technicians or manufacturers as soon as possible;
- When transporting again, please use the original packaging materials;
- If there is obvious damage to the machine casing, it should be replaced in a timely manner;
- When hanging lamps, it is necessary to verify that the hanging equipment can withstand more than 6 times the weight of the lamp. After installation, it is necessary to verify that the lamp cover and installation buckle are secure and undamaged. At the same time, a safety rope should be used as an auxiliary safety for the lamp and fixed on the truss;
- The light source inside this luminaire should be replaced by the manufacturer, its service agent, or a similarly qualified person;
- If you have any other questions about how to safely operate the equipment, please contact our technical personnel or call our service hotline;
- This product has a protection level of IP66 and can be used both indoors and outdoors;
- Avoid direct external strong light shining on the lens, which may cause the lens to focus and burn out internal components;
- Before turning off the lighting fixture, please adjust the zoom lens to the maximum angle (DMX value: 255), such as the position closest to the LED.

- Lighting fixtures should be kept clean and avoid prolonged use in overheated or dusty environments to prevent contact with chemical liquids;
 - When using the product, attention should be paid to avoiding serious or fatal injuries caused by fire, heat, electrical shock, and ultraviolet radiation. Before powering on or installing, read the instruction manual first. Follow the safety precautions for operation and pay attention to the warning signs on the instructions and equipment;
 - Only professionals are allowed to install, operate, and maintain lighting fixtures, and strictly follow the procedures stated in the operating instructions.
-
- The eyes cannot directly look at the luminous object;
 - Do not connect this device to any dimmer;
 - If visible damage occurs to the protective casing, lens, and display screen on the lighting fixture, it is considered as damage to the point of loss;
 - Please do not place any filters or other items at the light outlet, and do not replace non original parts;
 - The minimum safe illumination distance of the lamp is 1m.
-
- Before installation, please confirm that the power supply voltage used matches the voltage indicated on the light fixture. Each lighting fixture should be properly grounded and electrically installed according to relevant standards;
 - Please disconnect the power before repairing or cleaning the equipment;
 - During the operation of the lighting fixtures, touching the wires is prohibited to prevent electric shock;
 - If the external soft cable or wire of this lamp is damaged, the wire should be replaced by the manufacturer, its agent, or a similarly qualified person to avoid danger;
 - Avoid flammable liquids, water, or metal conductors from entering the interior of the lamp to prevent electric shock or fire. If any foreign objects enter the lamp, immediately cut off the power supply;
 - When multiple lamps are operated in series, the signal lines can be connected in multiple ways, but the power supply must be connected separately.
-
- The lighting fixtures work normally at -20 °C to 45 °C . When replacing any components or accessories in the equipment, ensure that the power is disconnected to prevent electric shock and injury;
 - The maximum surface temperature of the lamp during operation can reach 70 °C , please do not touch it with bare hands.
-
- The lighting fixtures must be installed in a sufficiently ventilated area, at least 0.5m away from adjacent surfaces, to ensure that no ventilation holes are blocked;
 - Do not install the lighting fixtures directly on flammable objects;
 - The minimum distance between all outer surfaces of the lamp and combustible materials is 0.5m.

2. Product Introduction

2.1 Dimensional drawings

298 × 205 × 362 mm

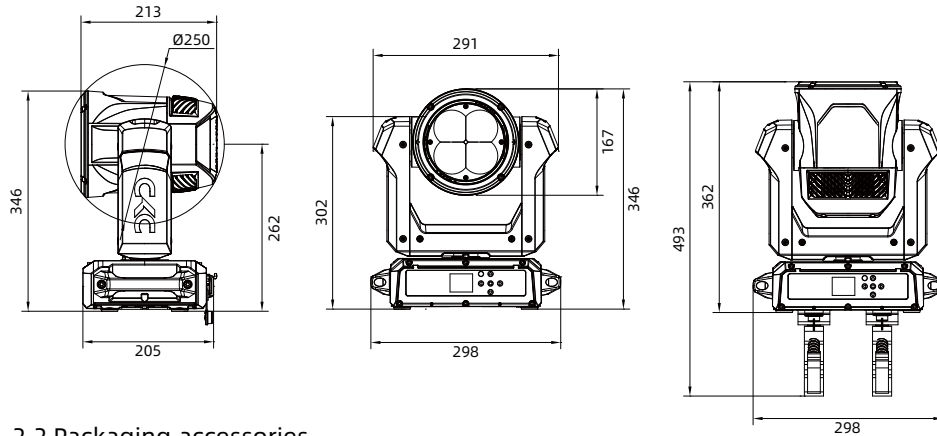

2.2 Packaging accessories

| Name | QTY | |
|---------------|-----|-----|
| Omega bracket | 2 | PCS |
| Clamp | 2 | PCS |
| Safety cable | 1 | PCS |

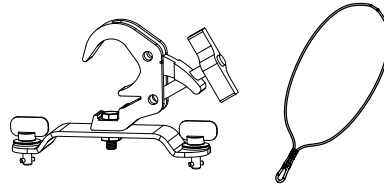

3. Main technical parameters of the equipment

Product execution standards: GB7000.1-2023, GB7000.217-2023, Q/YF-2017

● Electrical parameter

Rated input voltage: AC 100V-240V~ 50Hz/60Hz
 Rated power of the entire fixture: 320W
 Power factor: 0.99F
 Input Current: 220V 1.35A

● LED lifespan

> 20000 hours

● Pan/Tilt

Pan: infinite rotation (360°)
 Tilt: infinite rotation (360°)

● Optical system

LED source: 4 × 60W RGBL LED
 Output luminous flux: 4900 Lm
 Zoom Range: 4° ~ 55°
 CCT: 2400 ~ 8500K

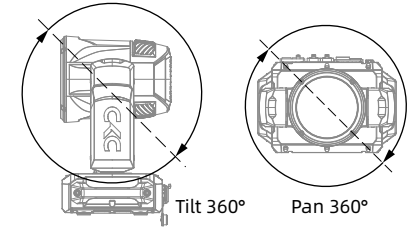

● Control and programming

Control channel: 21CH/25CH/37CH
 Protocol: DMX512, ArtNet/sACN, RDM
 Data connect: 3 or 5 pin XLR in/out

LED order

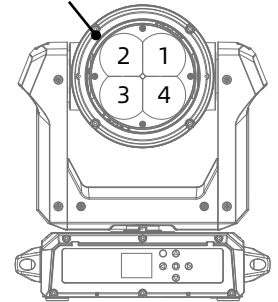

● Illumination map

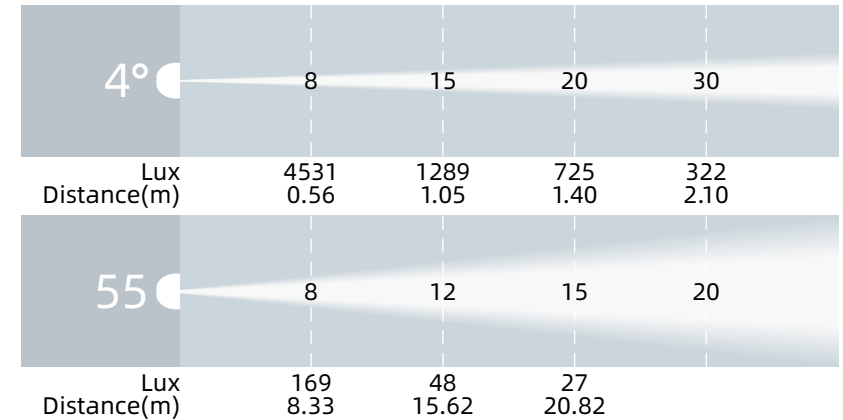

● Other effect function

Fast electronic strobe: 1~25Hz

● Other features and functions

Weight: 8.6 kg

4. Packaging and transportation

4.1 Disassemble packaging



Notice: After receiving the fixture, please unpack and check for any damage caused by transportation. If there is any damage caused by transportation, please do not use this fixture and contact the local technical personnel or manufacturer as soon as possible.

4.2 Equipment packaging

- 1). Disconnect the power supply before packaging the lighting fixtures to allow them to cool completely;
- 2). Flight cases can only be stacked in two layers and are not allowed to be reversed.

5. Installation Requirements Explanation

5.1 Clamp install

The lighting fixtures can be installed on the stage or on any direction of the truss, and the clamp can be quickly and easily locked onto

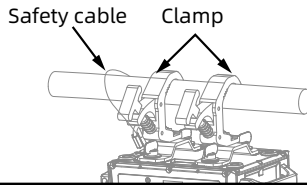



Warning !
 The lighting fixtures are divided into two versions: integrated light hook and normal. When using the integrated light hook version, the clamp is broken up and locked onto the truss. The normal version must use 2 clamps to secure the device and fasten it with a 1/4 rotation. Regardless of the version, one safety rope must be added and connected to the base hole, but be careful not to connect it to the handling handle.

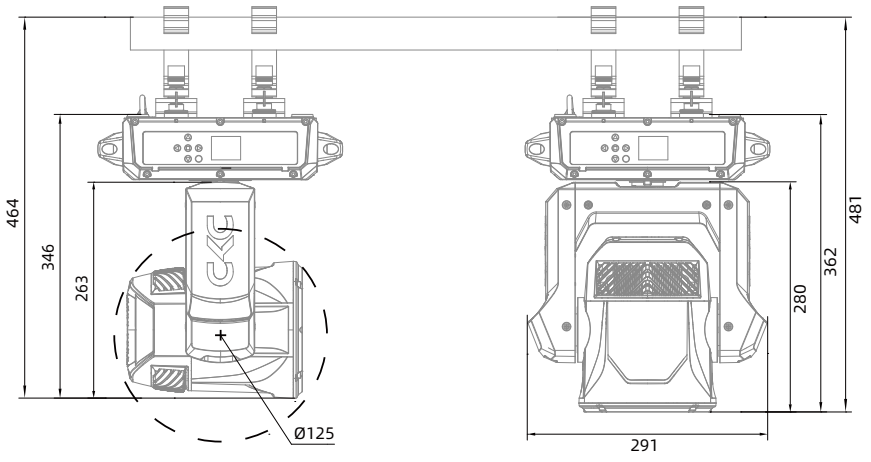

Quick lock and clamp install

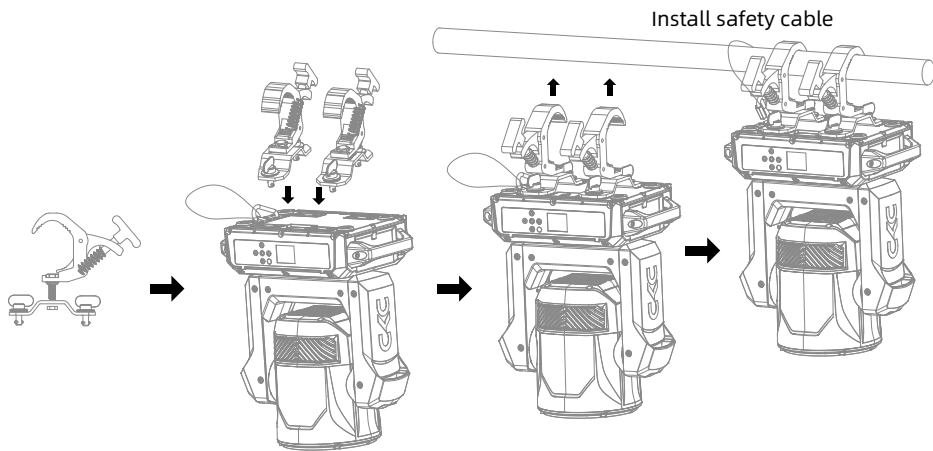

5.2 Equipment installation

- 1). Before installation, it is necessary to verify that the lamp hook and safety rope are not damaged, and that the installation object can withstand 6 times the total weight of the lamp and cable accessories;
- 2). Install the quick lock clamp on the base of the lamp body. Insert the clamp horizontally into the mounting hole of the base, rotate it clockwise 1/4 turn to lock it, and install the second clamp using the same method (the shape of the clamp should be based on the actual product).

5.3 Hanging Installation Diagram

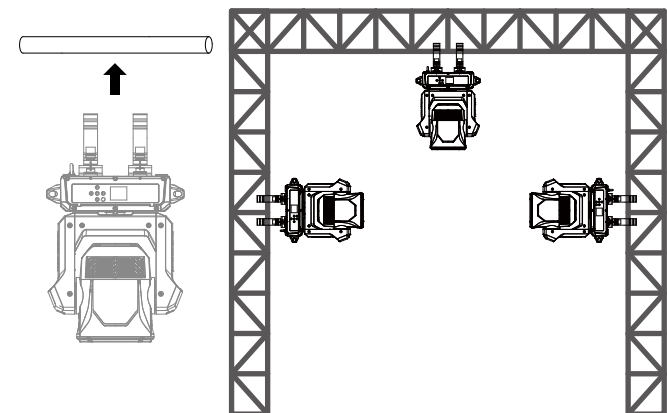

Reminder: External beam source may damage internal lighting fixtures

External beams from direct sunlight, lighting fixtures, and lasers that are directly focused onto the casing or penetrate the lens to illuminate the interior of the fixture may cause damage to the components. This is a common issue with all lighting fixtures and does not occur alone with CKC products. Although there is no way to completely prevent this problem from occurring, following the following guidelines can prevent potential damage.

When unpacking, installing, using, and stopping the operation of the lighting fixtures, please do not expose the transparency of the fixtures the mirror is exposed to direct sunlight, other lighting fixtures, or laser beams. Do not directly focus the beam of this device onto another lighting fixture.

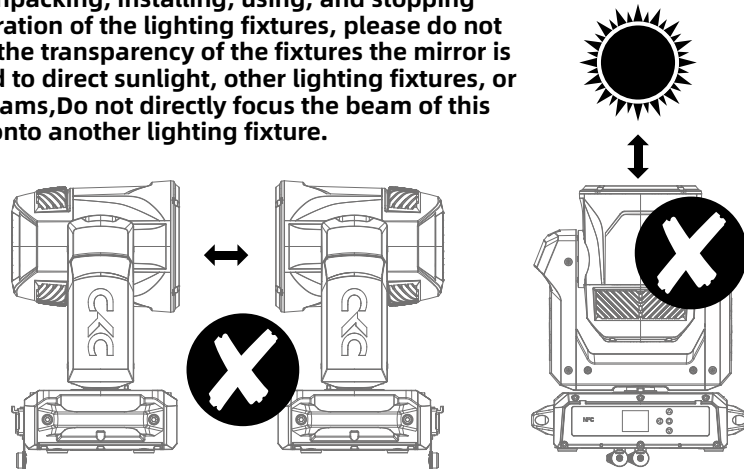

6. Power、Signal connect

6.1 Power and signal seat

- | | |
|-------------------------|--------------------|
| 1、Fuse holder | 2、Breathable valve |
| 3、Power input | 4、Power output |
| 5、Network output socket | |
| 6、Network input socket | |
| 7、DMX OUT | 8、DMX IN |

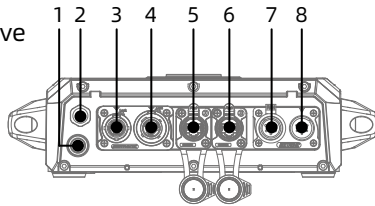

6.2 Power connect

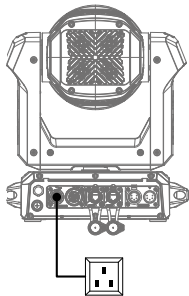

Connection method:

L(live wire) - brown wire

E(Ground wire) - yellow/green dual color line

N(Zero Line) - Blue Line

When connecting the power supply, please note that the voltage and frequency of the power supply must match the voltage and frequency marked on the light fixture. When multiple fixtures are used simultaneously, it is recommended to connect the power supply of each fixture separately, so that each fixture can be individually controlled for power on/off.

Attention: When connecting the power supply, the ground wire (yellow/green dual color wire) must be safely grounded and comply with all relevant electrical installation standards.

This product uses Powercon In/Out to connect power cords. Due to power limitations, a 2 square meter power cord can carry up to 8 products at 220V and 3 product at 110V.

Warning !

- Do not connect too many fixtures or overload a single power cord;
- Do not use power cords with damaged insulation layers, and do not place power cords on other wires;
- When the fixture is not in use or cleaned, please unplug the power cord; Do not forcefully unplug or drag the power cord directly.

6.3 Signal connect

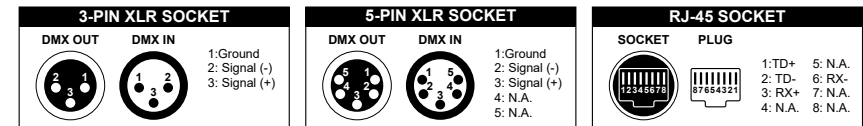

The lighting fixtures are equipped with standard DMX XLR or RJ-45 input and output sockets. Please use DMX512 shielded twisted pair signal cables or Category 5 or above network twisted pair cables for connection. The typical connection distance for DMX signal lines is 150 meters. When transmitting signals over long distances, a DMX512 signal amplifier must be added.

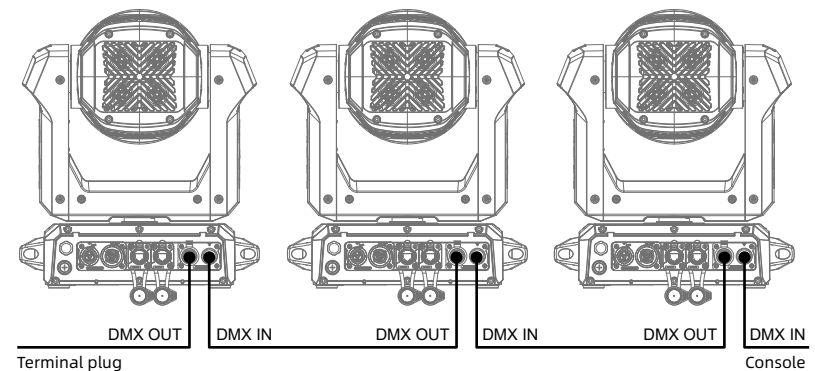

Connect a shielded twisted pair signal cable from the DMX output port of the controller to the DMX input port of the first device, and from the DMX output port of the first device to the DMX input port of the second device, and so on, until all the lamps are connected. Then install a terminal plug on the last 3 or 5 pin socket of each connected lamp output. (Weld a 4/1W, 120 Ω resistor between the 2 and 3 pins of a 3 or 5 core pin XLR plug).

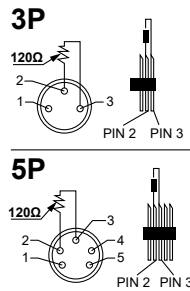

7. Control panel

7.1 Panel Introduction

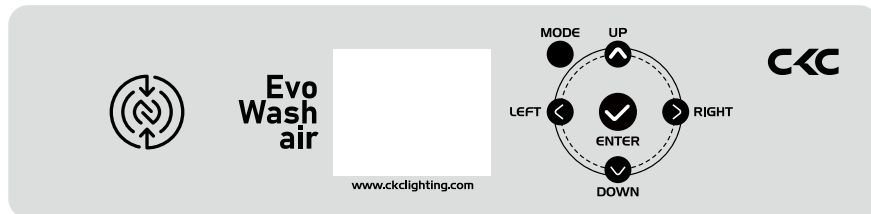

- Display: 1.8 LCD screen the operation panel has a rechargeable battery that allows you to access the menu to set the address code and make other settings without power on;
- NFC: The lighting fixtures do not require power on and can be directly set up, diagnosed, and perform other functions through the CKC app
- Press the MODE key to view or modify the lighting function settings, and press the UP, DOWN, LEFT, and RIGHT keys to select the function menu;
- Press the ENTER key to confirm your selected function menu, which will take you to the corresponding sub menu in the menu. Each menu item represents a specific function of the lighting fixture (as shown in the table below);
- Press the ENTER key to save your modifications or enter a submenu, and press the UP or DOWN key to modify values (increase or decrease values); Press the MODE key to return to the previous menu or exit.
- Press the MODE key to return to the previous menu or exit.

7.2. System menu

Note: The gray color block is the default setting value

| | |
|-------------------|---------------|
| Software Update | Please Wait.. |
| CKC | |
| EvoWash Air | |
| Ethernet Reset | |
| Temperature Check | |
| LED Temp:xxxC/F | |
| Head Temp:xxxC/F | |
| Base Temp: xxxC/F | |
| Motor Reset... | |
| Please Wait... | |

| | | | |
|-----------------|---|--|--|
| DMX | DMX Address | 001 - 512 | |
| | DMX Mode | Basic 21 Standard 25 Pixels 37 | |
| | No DMX Status | Hold Last Fade to Black Sun Protection | |
| | Protocol | Select Signal | Art-Net / sACN |
| | | Universe | 0-32767(Default = 1) |
| | | IP Address | Manual: 2.x.x.x Unique Static: 2.x.x.x/ 10.x.x.x/ 172.x.x.x/ 192.x.x.x |
| | | Subnet Mask | 255.0.0.0 |
| | | Ethernet DMX Out | Off/On |
| Network Switch | | Off/On | |
| Control | Manual Control | Pan Pan Fine Tilt Tilt Fine ... | |
| | Reset | All Pan Tilt Zoom | |
| | Self Test | All Dimmer Movement Color Mix Zoom | |
| Settings | Fan Mode | Studio/Low/High/Auto | |
| | Movement | Pan Invert | Off/On |
| | | Tilt Invert | Off/On |
| | | Pan Degree | 360/540 |
| | | Tilt Degree | 360/270 |
| | | PanTilt Path | Shortest Path / Continue Path |
| | | Pan /Tilt Speed | Smooth/Fast |
| | Pan/Tilt Feedback | Off/On | |
| Dim Curves | Linear Square Square Inverse S-Curve | | |

| | | |
|------------------|---|--------------------|
| Color Tuning | Highest CRI | |
| | Highest Output | |
| Output Balance | Bright | |
| | Uniform | |
| CCT Mode | Constant Mode | |
| | Max Mode | |
| Dim Modes | Standard | |
| | Stage | |
| | TV | |
| | Architectural Theatre | |
| LED Refresh Rate | 1200Hz, 3600Hz, 5000Hz, 10KHz,15KHz, 20KHz, 25KHz(Default = 1200Hz) | |
| LED Power Limit | 50% | |
| | 60% | |
| | 70% | |
| | 80% | |
| | 90% | |
| | 100% | |
| Display | Screen Delay | 10s - 5min (1 min) |
| | Screen Lock | Off/ON/ON1 |
| | FlipDisplay | Off/On/Auto |
| Reset Defaults | Yes / No | |
| Time | Current Time | xxxxxx H |
| | Total Run Time | xxxxxx H |
| | Last Run Time | xxxxxx H |
| | LED Time | xxxxxx H |
| Temperature | LED | xxxC/xxxF |
| | Head | xxxC/xxxF |
| | Base | xxxC/xxxF |
| Humidity | Head | xxx% |
| | Base | xxx% |
| Fan | Fan : xxxxRPM | |
| DMX Values | Pan Tilt ... | |
| Product IDs | RDM UID | 062B 0355 XXXX |
| Error Logs | Fixture Errors | |

Information

| | | |
|-----------------------|---------------------------------|---|
| Service (Passcode 50) | Software Version | 1U:V1.X.X 2U:V1.X.X 3U:V1.X.X 4U:V1.X.X 5U:V1.X.X |
| | Calibration | Pan Tilt ... |
| | Reset Last Run | Yes / No |
| | Reset Error Logs | Yes / No |
| | CCT MODE (Passcode 251) | Overheating mode |
| | Tint Calibration (Passcode 250) | FULL 2400K ... |

8. DMX channel table:

| Basic | Standard | Extend | Value | Function |
|-------|----------|--------|--------------------------------|-------------------------------|
| 1 | 1 | 1 | 0~255 | Pan |
| | | | | Left → Right |
| | 2 | 2 | 0~255 | Pan Fine |
| | | | | Fine Position |
| 2 | 3 | 3 | 0~255 | Tilt |
| | | | | Forward → Backward |
| | 4 | 4 | 0~255 | Tilt Fine |
| | | | | Fine Position |
| 3 | 5 | 5 | 0-2 3-127 128 129-255 | Pan Rotation |
| | | | | Disabled |
| | | | | Clockwise Fast → Slow |
| | | | | Stop |
| 4 | 6 | 6 | 0-2 3-127 128 129-255 | Tilt Rotation |
| | | | | Disabled |
| | | | | Clockwise Fast → Slow |
| | | | | Stop |
| | 7 | 7 | 0-255 | Counter-clockwise Slow → Fast |
| | | | | Pan / Tilt Speed |
| | | | | Max → Min Speed |

| | | | | | |
|----|----|----|-------|-----------------|----------------------------|
| 5 | 8 | 8 | 0-255 | Dimmer | |
| | | | | 0 → 100% | |
| | 9 | 9 | 0-255 | Dimmer Fine | |
| | | | | Fine Adjustment | |
| 6 | 10 | 10 | | Strobe | |
| | | | | 0-31 | Closed |
| | | | | 32-63 | Open |
| | | | | 64-95 | Strobe effect slow to fast |
| | | | | 96-127 | Open |
| | | | | 128-159 | Pulse Effect |
| | | | | 160-191 | Open |
| | | | | 192-223 | Random Slow → Fast |
| | | | | 224-255 | Open |
| 7 | 11 | | 0-255 | Red | |
| | | | | 0 → 100% | |
| 8 | 12 | | 0-255 | Green | |
| | | | | 0 → 100% | |
| 9 | 13 | | 0-255 | Blue | |
| | | | | 0 → 100% | |
| 10 | 14 | | 0-255 | Lime | |
| | | | | 0 → 100% | |
| | | 11 | 0-255 | Red 1 | |
| | | | | 0 → 100% | |
| | | 12 | 0-255 | Green 1 | |
| | | | | 0 → 100% | |
| | | 13 | 0-255 | Blue 1 | |
| | | | | 0 → 100% | |
| | | 14 | 0-255 | Lime 1 | |
| | | | | 0 → 100% | |
| | | 15 | 0-255 | Red 2 | |
| | | | | 0 → 100% | |
| | | 16 | 0-255 | Green 2 | |
| | | | | 0 → 100% | |
| | | 17 | 0-255 | Blue 2 | |
| | | | | 0 → 100% | |

| | | | | | |
|----|----|----|-------|-------------------------------|---------------------------------|
| | | 18 | 0-255 | Lime 2 | |
| | | | | 0 → 100% | |
| | | 19 | 0-255 | Red 3 | |
| | | | | 0 → 100% | |
| | | 20 | 0-255 | Green 3 | |
| | | | | 0 → 100% | |
| | | 21 | 0-255 | Blue 3 | |
| | | | | 0 → 100% | |
| | | 22 | 0-255 | Lime 3 | |
| | | | | 0 → 100% | |
| | | 23 | 0-255 | Red 4 | |
| | | | | 0 → 100% | |
| | | 24 | 0-255 | Green 4 | |
| | | | | 0 → 100% | |
| | | 25 | 0-255 | Blue 4 | |
| | | | | 0 → 100% | |
| | | 26 | 0-255 | Lime 4 | |
| | | | | 0 → 100% | |
| 11 | 15 | 27 | | Variable CCT | |
| | | | | 0-23 | Open (6000K) |
| | | | | 24-85 | 2400K → 8500K |
| | | 28 | | 86-255 | 8500K |
| | | | | 0 | CTO |
| 12 | 16 | 28 | | 1-254 | CTO fade to Color Mix |
| | | | | 255 | Color Mix |
| 13 | 17 | 29 | | Tint | |
| | | | | 0 | Idle |
| | | | | 1-127 | Full Minus Green to Neutral |
| | | | | 128 | Neutral White |
| | | | | 129-255 | Neutral to Full Plus Green |
| | | | | Virtual Wheel Color Forground | |
| | | | | 0 | Open |
| | | | | 1-179 | Virtual Swatch Book (See Sheet) |
| | | | | | Scroll |
| | | | | 180-201 | Clockwise Fast → Slow |
| | | | | 202-207 | Stop |

| | | | | |
|---------|---------------------------------|----|---------|-------------------------------|
| 14 | 18 | 30 | 208-229 | Counter-clockwise Slow → Fast |
| | | | 230-234 | Open |
| | | | | Random Slots |
| | | | 235-239 | Fast |
| | | | 240-244 | Medium |
| | | | 245-249 | Slow |
| | | | 250-255 | Open |
| | | | 15 | 19 |
| 0 | Open | | | |
| 1-179 | Virtual Swatch Book (See Sheet) | | | |
| | Scroll | | | |
| 180-201 | Clockwise Fast → Slow | | | |
| 202-207 | Stop | | | |
| 208-229 | Counter-clockwise Slow → Fast | | | |
| 230-234 | Open | | | |
| | Random Slots | | | |
| 235-239 | Fast | | | |
| 240-244 | Medium | | | |
| 245-249 | Slow | | | |
| 250-255 | Open | | | |
| 16 | 20 | 32 | | Patterns Programs |
| | | | 000-009 | No Program |
| | | | 010-019 | Program 1 |
| | | | 020-029 | Program 2 |
| | | | 030-039 | Program 3 |
| | | | 040-049 | Program 4 |
| | | | 050-059 | Program 5 |
| | | | 060-069 | Program 6 |
| | | | 070-079 | Program 7 |
| | | | 080-089 | Program 8 |
| | | | 090-099 | Program 9 |
| | | | 100-109 | Program 10 |
| | | | 110-119 | Program 11 |
| | | | 120-129 | Program 12 |
| | | | 130-139 | Program 13 |
| 140-149 | Program 14 | | | |

| | | | | | | | |
|----|----|----|-----------|---------------------------|----|-------|---------------|
| 17 | 21 | 33 | 150-159 | Program 15 | | | |
| | | | 160-169 | Program 16 | | | |
| | | | 170-179 | Program 17 | | | |
| | | | 180-189 | Program 18 | | | |
| | | | 190-199 | Program 19 | | | |
| | | | 200-209 | Program 20 | | | |
| | | | 210-255 | No used | | | |
| | | | 0 - 4 | Static step 1 | | | |
| | | | 5 - 9 | Static step 2 | | | |
| | | | 10 - 14 | Static step 3 | | | |
| | | | 15 - 19 | Static step 4 | | | |
| | | | 20 - 24 | Static step 5 | | | |
| 18 | 22 | 34 | 25 - 29 | Static step 6 | | | |
| | | | 30 - 34 | Static step 7 | | | |
| | | | 35 - 39 | Static step 8 | | | |
| | | | 40 - 145 | Chase Forward F > S | | | |
| | | | 146 - 149 | Stop | | | |
| | | | 150 - 255 | Chase Backward S > F | | | |
| | | | 0-255 | Programs Fade | | | |
| | | | | Zoom | | | |
| | | | 19 | 23 | 35 | 0-255 | Narrow → Wide |
| | | | | | | | Dimmer Modes |
| 20 | 24 | 36 | 0-20 | Standard | | | |
| | | | 21-40 | Stage | | | |
| | | | 41-60 | TV | | | |
| | | | 61-80 | Architectural | | | |
| | | | 81-100 | Theatre | | | |
| | | | 101-255 | Default to Unit Setting | | | |
| | | | | Control: | | | |
| | | | 0-015 | No function | | | |
| | | | 016-020 | Invert Pan on (Hold 3s) | | | |
| | | | 021-030 | Invert Pan off (Hold 5s) | | | |
| | | | 031-035 | Invert Tilt on (Hold 3s) | | | |
| | | | 036-040 | Invert Tilt off (Hold 5s) | | | |
| | | | 041-045 | Fan Auto (Hold 3s) | | | |
| | | | 046-050 | Fan Studio (Hold 3s) | | | |
| | | | 051-055 | Fan Low (Hold 3s) | | | |

| | | | | |
|----|----|----|---------|-------------------------------|
| 21 | 25 | 37 | 056-060 | Fan High (Hold 3s) |
| | | | 061-065 | Linear |
| | | | 066-070 | Square(Default) |
| | | | 071-075 | Inverse Square |
| | | | 076-080 | S-Curve |
| | | | 081-085 | Led Freq. 1200 Hz (hold 3s) |
| | | | 086-090 | Led Freq. 3600 Hz (hold 3s) |
| | | | 091-100 | Led Freq. 5000 Hz (hold 3s) |
| | | | 101-105 | Led Freq. 10.000 Hz (hold 3s) |
| | | | 106-110 | Led Freq. 15.000 Hz (hold 3s) |
| | | | 111-115 | Led Freq. 20.000 Hz (hold 3s) |
| | | | 116-120 | Led Freq. 25.000 Hz (hold 3s) |
| | | | 121-125 | Reset Pan/Tilt (Hold 3s) |
| | | | 126-130 | Reset Zoom (Hold 3s) |
| | | | 131-135 | Reset All Functions (Hold 3s) |
| | | | 136-140 | Highest CRI |
| | | | 141-145 | Highest Output |
| | | | 146-150 | Bright |
| | | | 151-155 | Uniform |
| | | | 156-160 | Sun Protection ON |
| | | | 161-165 | Sun Protection OFF |
| | | | 166-255 | No function |

| | | |
|----|-----|-------------------|
| 15 | 135 | deep golden amber |
| 16 | 24 | scarlet |
| 17 | 106 | primary red |
| 18 | 26 | bright red |
| 19 | 27 | medium red |
| 20 | 19 | fire |
| 21 | 157 | pink |
| 22 | 36 | medium pink |
| 23 | 111 | dark pink |
| 24 | 128 | bright pink |
| 25 | 148 | bright rose |
| 26 | 332 | special rose pink |
| 27 | 793 | vanity fair |
| 28 | 113 | magenta |
| 29 | 46 | dark magenta |
| 30 | 48 | rose purple |
| 31 | 126 | mauve |

| | | |
|--------|-----|-------------------|
| 46 | 116 | medium blue green |
| 47 | 90 | dark yellow green |
| 48 | 139 | primary green |
| 49 | 122 | fern green |
| 50 | 89 | moss green |
| 51 | 124 | dark green |
| 52 | 88 | lime green |
| 53 | 138 | pale green |
| 54 | 203 | Quarter CT Blue |
| 55 | 202 | Half CT Blue |
| 56 | 201 | FULL CT Blue |
| 57 | 200 | double CT Blue |
| 58 | 206 | Quarter CT Orange |
| 59 | 205 | Half CT Orange |
| 60 | 204 | FULL CT Orange |
| 61-179 | | No function |

Virtual Switch Book

| Value | Filter Number | Name | Value | Filter Number | Name |
|-------|---------------|----------------|-------|---------------|----------------|
| 1 | 7 | pale yellow | 32 | 49 | medium purple |
| 2 | 103 | straw | 33 | 58 | lavender |
| 3 | 151 | gold tint | 34 | 199 | palace blue |
| 4 | 100 | spring yellow | 35 | 119 | dark blue |
| 5 | 10 | medium yellow | 36 | 132 | medium blue |
| 6 | 101 | yellow | 37 | 120 | deep blue |
| 7 | 104 | deep amber | 38 | 165 | daylight blue |
| 8 | 15 | deep straw | 39 | 161 | slate blue |
| 9 | 179 | loving amber | 40 | 118 | light blue |
| 10 | 21 | gold amber | 41 | 68 | sky blue |
| 11 | 105 | orange | 42 | 143 | pale navy blue |
| 12 | 158 | deep orange | 43 | 131 | marine blue |
| 13 | 22 | dark amber | 44 | 115 | peacock blue |
| 14 | 778 | millenium gold | 45 | 172 | lagoon blue |

9. Control circuit diagram

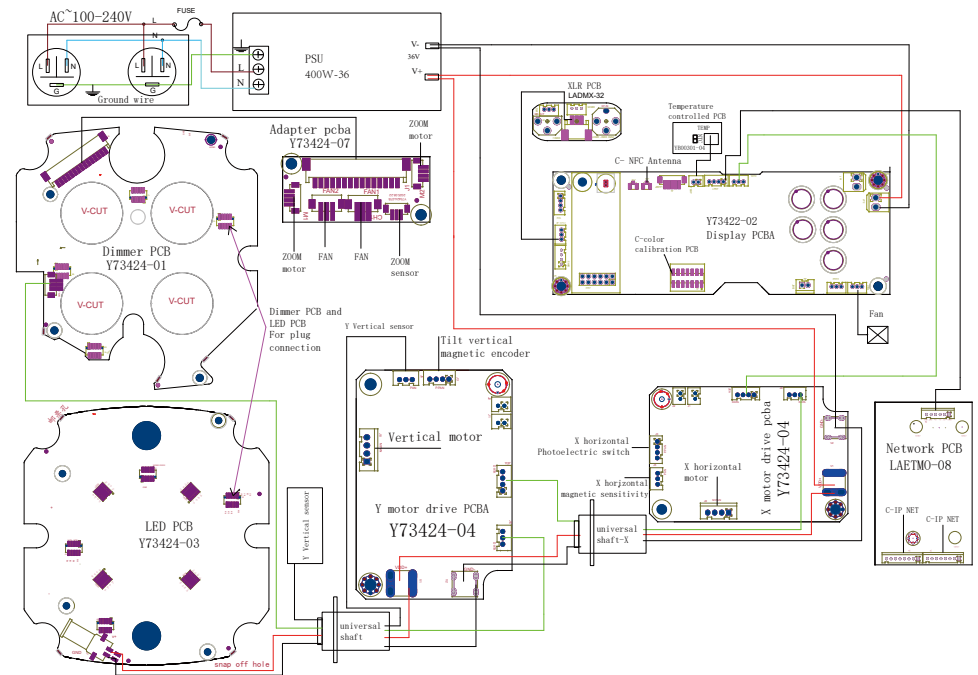

10. Regular maintenance

10.1 Cleaning and maintenance

Lighting fixtures require daily cleaning and maintenance, and their service life largely depends on the operating environment and standards. If you have any questions, please consult our technical engineers for advice. Maintenance and repair work not included in this book should be entrusted to our qualified technical engineers.

 **Attention!** Damage caused by dust, e-liquid, or other reasons, as well as abnormal use, is not covered by the warranty.



Warning !

Before opening any lid, disconnect the power supply. Cleaning optical components requires gentle wiping as the coating surface is prone to scratching. Do not use damaging liquids or hard objects, as they may damage the plastic or coating surface.

- When the lens is cracked or otherwise damaged, it should be replaced in a timely manner;
- When the brightness significantly decreases, the LED may have reached its expiration date and should be replaced in a timely manner;
- When the fixture cannot start, please check if the fixture power fuse is blown. If it is blown, a fuse of the same specification must be used for installation;
- The fixture is equipped with a temperature protection device. When the temperature is too high, the protection device will automatically reduce power.
- When this situation occurs, please check whether the fan is running normally, whether the fan and fan mesh are clogged with dust, identify the fault and repair it before starting the fixture. Please note that only qualified technicians are allowed to carry out maintenance work;
- To maintain smooth movement of the focusing lens, it is recommended to lubricate the guide rail of the focusing lens every three months. Excellent and high-temperature resistant lubricating grease should be used, and excessive grease should not be used as it can easily dirty adjacent components.

10.2 Fault analysis and handling

| Fault description | Analysis | Processing method |
|--------------------------|---|-------------------|
| No action after power on | Check if the power switch is turned on | Turn on |
| | Check if the fuse is blown | Replace |
| | Check if the output of the psu is normal | Detecting voltage |
| | Check if poor contact in the internal circuit | Reconnect |

| | | |
|---|--|--------------------------------|
| Uncontrolled lighting fixtures | Check if the DMX signal cable is connected correctly (If there is no signal, the display screen will flash) | Reconnect or replace |
| | Check if the address code is correct and if the DMX mode of the lighting fixture matches the settings | Reconfirm |
| | The main control pcb is damaged | Replace |
| Not bright | LED aging or damaged | Replace |
| | Power pcb malfunction | Check/ replace |
| | Loose or poor contact of the circuit | Reconnect |
| | Switching power supply malfunction | Replace |
| Automatically turn off or dim the lights | LED aging | Replace |
| | Damaged cooling fan or abnormal wind speed | Replace |
| | Check the power output of the fan on the power circuit pcb | Check/ replace |
| Weak light efficiency and uneven light spot | The temperature control switch is damaged | Replace |
| | LED aging | Replace |
| | LED not centered with the lens | Adjust the light guide column |
| Impure color | The optical mirror has accumulated dust or stains | Clean |
| | The optical mirror is damaged | Replace |
| Head or base fan stops rotating | Weakening of light efficiency | Replace led pcb |
| | Check if the fan leads are installed properly or disconnected | Re connect |
| | Check if the fan is damaged | Replace |
| | Check if there are any other interferences within the operating range of the fan | Adjust the interference object |
| |  Attention! The above analysis is for abnormal reference only. Non professionals are not allowed to disassemble and repair the machine | |

