

CKC

FC Pendant 200

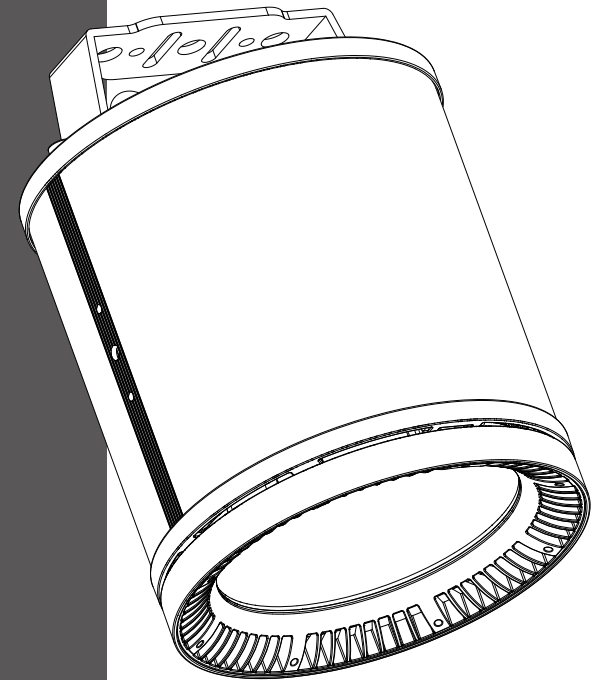

CKC LIGHTING CO.,LTD

Addr.:335 Nansha Avenue, Tung Chung Town,
Nansha District, Guangzhou City, China.
TEL: (020)3920 4506 FAX: (020)3920 4631
WEB: www.ckclighting.com

www.ckclighting.com



Before carrying out any installation, maintenance, or cleaning of the lighting fixtures, please confirm that the power has been cut off! Before using this fixture, please read this manual. Our company reserves the right to change product design and specifications without prior notice.

CONTENTS

1. Security Warning Information	1
2. Product Introduction	3
2.1 Exterior dimensions	3
2.2 Fixture packaging accessories	3
3. Main technical parameters of the equipment	3
4. Packaging and transportation	4
4.1 Disassemble packaging	4
4.2 Equipment installation	4
5. Installation Requirements Explanation	4
5.1 Clamp installation	4
5.2 Fixture installtion	5
5.3 Hanging Installation Diagram	5
6. Power and signal connection	6
6.1 Power and signal socket	6
6.2 Power Connect	6
6.3 Signal Connect	7
7. Control panel	7
7.1 Panel Introduction	7
7.2 System menu	8
8. DMX control channel table	10
9. Control circuit diagram	14
10. Regular maintenance	14
10.1 Cleaning and maintenance	14
10.2 Fault analysis and handling	15

★ Statement ★

- This manual contains important information on safe use and installation. Please read it carefully and follow the requirements for operation and installation. Please keep this manual properly;
- The equipment has good performance and complete packaging when it leaves the factory. The operator should strictly follow the warning items and operating instructions stated in the manual. Any malfunction or damage caused by misuse or neglect of the manual is not within the scope of our company's responsibility and warranty;
- The relevant information in this manual is for reference only. All lighting products are subject to the actual product. Any changes will not be notified separately, and our company reserves the right of final interpretation.

1. Security Warning Information



Attention !

Please read the safety requirements information in this section carefully before installing, powering on, operating, or repairing the lighting fixtures.



- This product is for professional use and is not suitable for other purposes;
- After receiving the lighting fixtures, please check if the packaging is complete and unpack to check if the equipment has been damaged due to transportation. If there is any damage caused by transportation, please do not use this lamp and contact local technicians or manufacturers as soon as possible;
- When transporting again, please use the original packaging materials;
- If there is obvious damage to the machine casing, it should be replaced in a timely manner;
- When hanging lamps, it is necessary to verify that the hanging equipment can withstand more than 6 times the weight of the lamp. After installation, it is necessary to verify that the lamp cover and installation buckle are secure and undamaged. At the same time, a safety rope should be used as an auxiliary safety for the lamp and fixed on the truss;
- The light source inside this luminaire should be replaced by the manufacturer, its service agent, or a similarly qualified person;
- If you have any other questions about how to safely operate the equipment, please contact our technical personnel or call our service hotline;
- This product has a protection level of IP30 and is suitable for indoor use;
- Avoid direct external strong light shining on the lens, which may cause the lens to focus and burn out internal components.



- Lighting fixtures should be kept clean and avoid prolonged use in overheated or dusty environments to prevent contact with chemical liquids;
- When using the product, attention should be paid to avoiding serious or fatal injuries caused by fire, heat, electrical shock, and ultraviolet radiation. Before powering on or installing, read the instruction manual first. Follow the safety precautions for operation and pay attention to the warning signs on the instructions and equipment;
- Only professionals are allowed to install, operate, and maintain lighting fixtures, and strictly follow the procedures stated in the operating instructions.



- The eyes cannot directly look at the luminous object;
- Do not connect this device to any dimmer;
- If visible damage occurs to the protective casing, lens, and display screen on the lighting fixture, it is considered as damage to the point of loss;
- Please do not place any filters or other items at the light outlet, and do not replace non original parts;
- The minimum safe illumination distance of the lamp is 1m.



- Before installation, please confirm that the power supply voltage used matches the voltage indicated on the light fixture. Each lighting fixture should be properly grounded and electrically installed according to relevant standards;
- Please disconnect the power before repairing or cleaning the equipment;
- During the operation of the lighting fixtures, touching the wires is prohibited to prevent electric shock;
- If the external soft cable or wire of this lamp is damaged, the wire should be replaced by the manufacturer, its agent, or a similarly qualified person to avoid danger;
- Avoid flammable liquids, water, or metal conductors from entering the interior of the lamp to prevent electric shock or fire. If any foreign objects enter the lamp, immediately cut off the power supply;
- When multiple lamps are operated in series, the signal lines can be connected in multiple ways, but the power supply must be connected separately.



- The lighting fixtures work normally at -20 °C to 45 °C . When replacing any components or accessories in the equipment, ensure that the power is disconnected to prevent electric shock and injury;
- The maximum surface temperature of the lamp during operation can reach 59 °C , please do not touch it with bare hands.



- The lighting fixtures must be installed in a sufficiently ventilated area, at least 0.5m away from adjacent surfaces, to ensure that no ventilation holes are blocked;
- Do not install the lighting fixtures directly on flammable objects;
- The minimum distance between all outer surfaces of the lamp and combustible materials is 0.5m.

2. Product Introduction

2.1 Exterior dimensions of lighting fixtures

196 × 196 × 273 mm

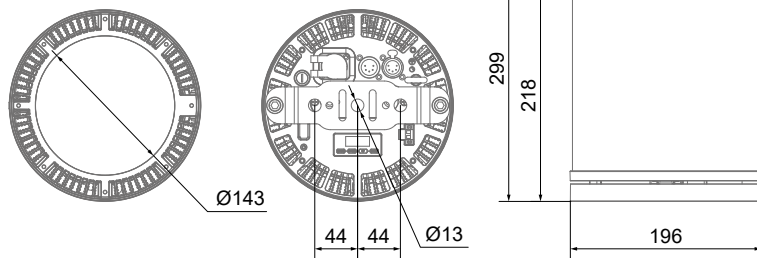

2.2 Packaging accessories

Name	QTY
Clamp	1 PCS
Safety cable	1 PCS

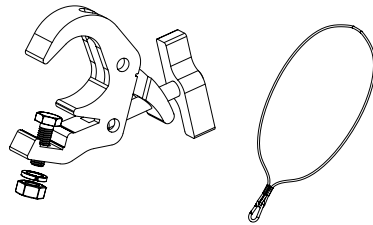

3. Main technical parameters of the equipment

Product execution standards: GB43472-2:2023、GB/T 7000.1-2023、GB/T 7000.217-2023

● Electrical parameter

Rated input voltage: AC 100V-240V~ 50Hz/60Hz
 Rated input power: 150 W
 Power factor: 0.999F
 Input Current: 0.669A 220V

● Source lifespan

> 20000 hours

● Optical system

Source: 72 × 3.5W RGBWL LED
 Output luminous flux: 6800 Lm
 Beam angle: 36°
 Field angle: 79°
 CCT: 2400K-8500K

● Control and programming

Control channel: 1CH/4CH/5CH/10CH/10CH/17CH/4CH/9CH
 Protocol: DMX512, RDM
 Data connect: 3 pin or 5pin signal in/out

● Illumination draw

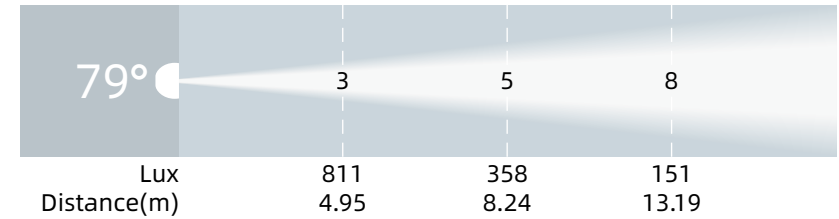

● Other effect function

Fast electronic strobe: 1~25Hz
 Dimming Mode: 27

● Other features and functions

Weight: 5.2 KG

4. Packaging and transportation

4.1 Disassemble packaging



Notice: After receiving the fixture, please unpack and check for any damage caused by transportation. If there is any damage caused by transportation, please do not use this fixture and contact the local technical personnel or manufacturer as soon as possible.

4.2 Equipment packaging

- 1). Disconnect the power supply before packaging the lighting fixtures to allow them to cool completely;
- 2). Flight cases can only be stacked in two layers and are not allowed to be reversed.

5. Installation Requirements Explanation

5.1 Clamp install

The lighting fixtures can be installed on the stage or on any direction of the truss, and the clamp can be quickly and easily locked onto the truss.

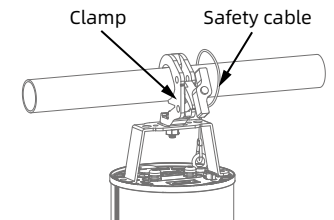

Warning !

Fixture can be used to fix the equipment, and a safety rope must be connected to the safety hook. Note that it cannot be connected to the handle.

Installation of clamps and safety cable

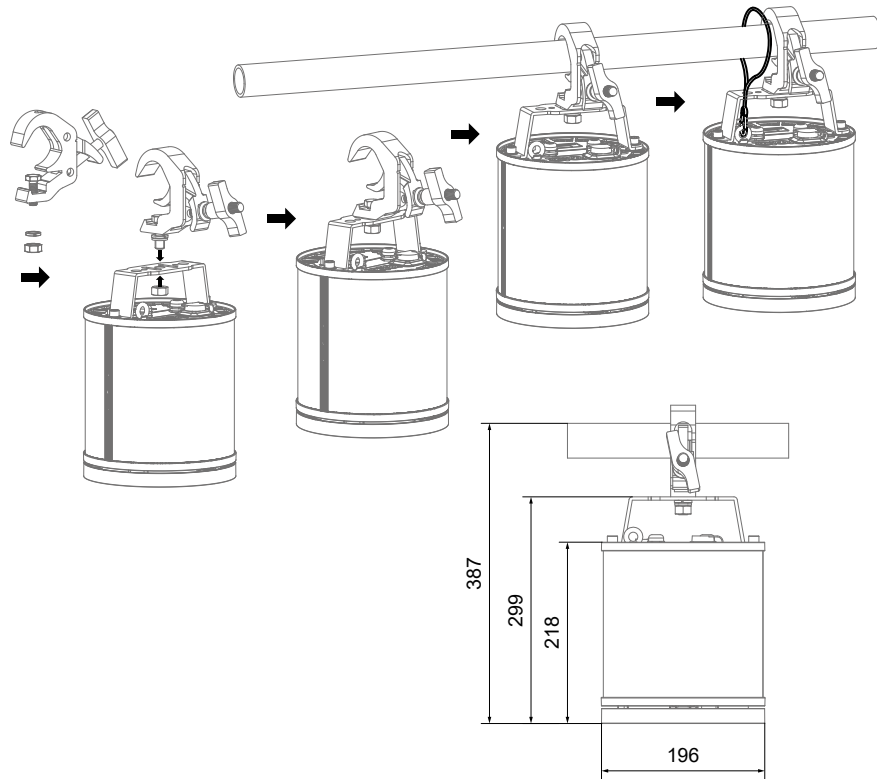

5.2 Equipment installation

- 1). Before installation, it is necessary to verify that the lamp hook and safety rope are not damaged, and that the installation object can withstand 6 times the total weight of the lamp and cable accessories;
- 2). The clamp is installed on the handle. Insert the clamp into the handle mounting hole horizontally and tighten it with bolts (the shape of clamp shall be subject to the actual object)..

5.3 Hanging Installation Diagram

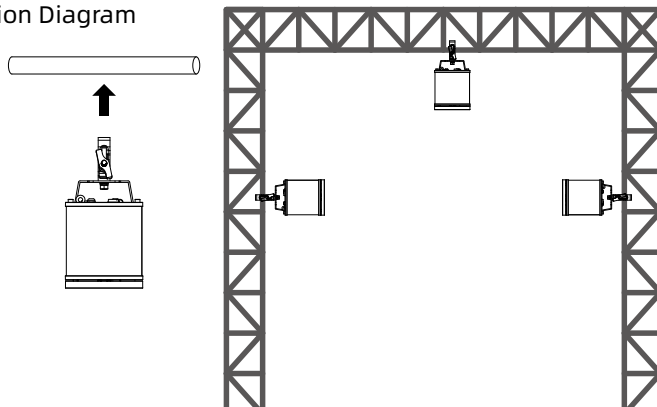

6. Power、Signal connect

6.1 Power and signal socket

1. EXT power socket AC input
2. Fuse holder
3. DMX wireless indicator light
4. INT lead AC input
5. EXT.INT selection
6. DMX 5-pin male
7. DMX 5-pin female
8. Safety clamps
9. 10V dimmer lead to socket+lead to DMX socket
10. Emergency light battery controller output interface

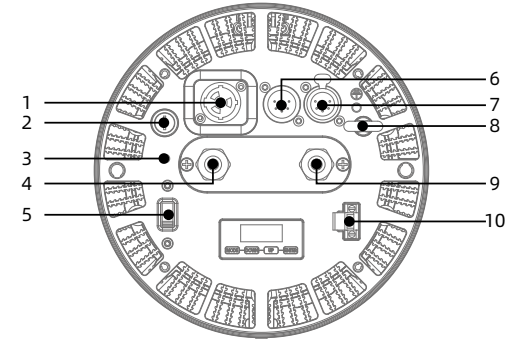

6.2 Power connect

Connection method:

- L**(live wire) - brown wire
- E**(Ground wire) - yellow/green dual color line
- N**(Zero Line) - Blue Line

When connecting the power supply, please note that the voltage and frequency of the power supply must match the voltage and frequency marked on the light fixture. When multiple fixtures are used simultaneously, it is recommended to connect the power supply of each fixture separately, so that each fixture can be individually controlled for power on/off.

Attention: When connecting the power supply, the ground wire (yellow/green dual color wire) must be safely grounded and comply with all relevant electrical installation standards.

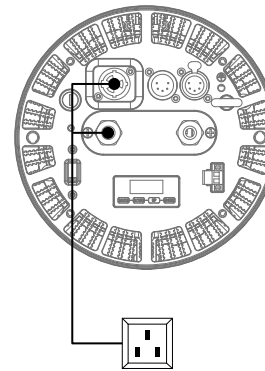

Power In

This product uses Powercon In/Out to connect power cords. Due to power limitations, a 2 square meter power cord can carry up to 1 products at 220V.

Warning !

- Do not connect too many fixtures or overload a single power cord;
- Do not use power cords with damaged insulation layers, and do not place power cords on other wires;
- When the fixture is not in use or cleaned, please unplug the power cord; Do not forcefully unplug or drag the power cord directly.

6.3 Signal connect

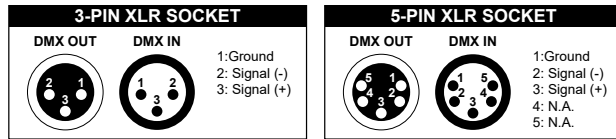

The lighting fixtures are equipped with standard DMX XLR input and output sockets. Please use DMX512 shielded twisted pair signal cables or Category 5 or above network twisted pair cables for connection. The typical connection distance for DMX signal lines is 150 meters. When transmitting signals over long distances, a DMX512 signal amplifier must be added.

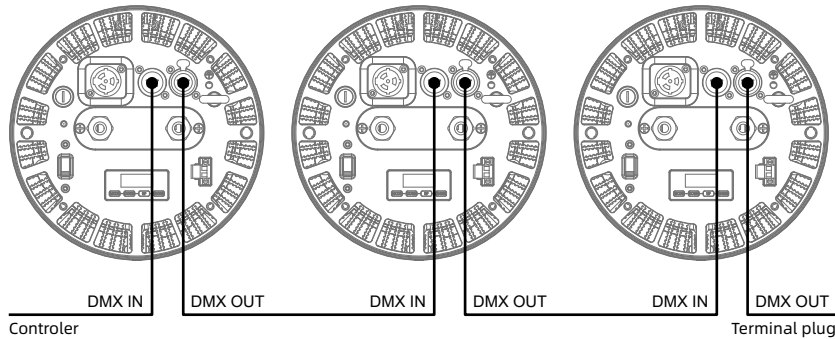

Connect a shielded twisted pair signal cable from the DMX output port of the controller to the DMX input port of the first device, and from the DMX output port of the first device to the DMX input port of the second device, and so on, until all the lamps are connected. Then install a terminal plug on the last 3 or 5 pin socket of each connected lamp output. (Weld a 4/1W, 120 Ω resistor between the 2 and 3 pins of a 3 or 5 core pin XLR plug).

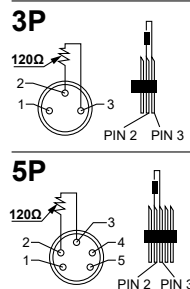

7. Control panel

7.1 Panel Introduction

- Adopting a OLED display screen;
- Press the MODE key to view or modify fixture function settings, and press UP and DOWN;
- Press the ENTER key to confirm your selected function menu, which will take you to the corresponding sub menu in the menu. Each menu item represents a specific function of the lighting fixture (as shown in the table below);
- Press the ENTER key to save your modifications or enter a submenu, and press the UP or DOWN key to modify values (increase or decrease values);
- Press the MODE key to return to the previous menu or exit.

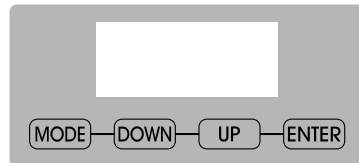

7.2. System menu

Note: The gray color block is the default setting value

Software update Please wait			
Menu Option	Level 1	Level 2	
DMX Settings	DMX Address	001 - 512	
	DMX Channel Mode	Dimmer 1CH	
		Dimmer Color 4CH	
		RGBWL 5CH	
		RGBWL 16bit 10CH	
		Standard 10CH	
		Extended 17CH	
		HSI 4CH	
	HSI Extended 9CH		
	No DMX Status	Hold Last	Please refer to the attached table of NO DMX for specific functions
Fade to black			
Standalone			
Priority	0-10V	DMX	
	DMX	Priority DMX	
Dimmer	0-10V	Priority 10V switch	
	000%-100%	total	
Color Temperature	2400-8500K (Default = 2700K)		
Virtual Color	Swatch Book	Fixed color (see color chart 1-53 for details)	
	Color Scroll	Forward rotation, speed 01-22	
	Color C-Scroll	Reverse rotation, speed 01-22	
Standalone	Random Slots		
	Fast/Medium/Slow		
Fade Time	0-60s (10s)	Gradient time (fadetime in NO DMX)	
0-10V Contact	ON / OFF	Using a 10V switch (dimmer is ineffective when turned on)	
Alarm Contact	ON / OFF	Warning switch When short circuited, light up the standalone color	
Master	ON / OFF		
	Slave		
Dim Modes	Standard		
	Stage		
	TV		
	Architectural		
	Theatre		
	Stage 2		
	Dim Speed 05-10S		
Dim Curves	Linear		
	Square		
	Square Inverse		
	S-Curve		

Personality	E-Fly Settings	Set EFly channel 00~14 Enable E-Fly YES / NO
	LED Refresh Rate	900~1500, 2500, 4000, 5000, 6000, 10KHz, 15KHz, 20KHz, 25KHz (1200Hz)
	LED Power Limit	50,60,70,80,90,100%
	Display	Screen Saver Delay 1-10
Screen Lock OFF - 10 minutes (Default = 30s)		
Rotate Display 180° YES / NO		
Service (PW:050)	Calibration	Red 000-255
		Green 000-255
		Blue 000-255
		White 000-255
		Lime 000-255
	Factory Restore YES / NO	
	Edit RDM UID xxxxxx	
Manual Control	Red	000-255
	Green	000-255
	Blue	000-255
	White	000-255
	Lime	000-255
	Dimmer	000-255
	Dimmer Fine	000-255
	Strobe	000-255
Info.	Fixture Life Time	Power On Time xxxxxx Hours
	Fixture Last Run Time	Power On TimAbleRes xxxxxx Hours
		Power On Time Reset (PW:050)
	Total Lamp Hours	xxxxxx Hours
	Fixture Temp	Current xxx F / xxx C
		Max Resettable xxx F / xxx C
		Max Not Resettable xxx F / xxx C
		Last Max Temp Reset (PW:038)
	DMX Values	Dimmer xxx
		Strobe xxx
...		
Product ID's	RDM UID	

Error Logs	Fixture Errors
	Reset Error Log (PW:050) YES / NO
Software Version	V1.01

8. DMX channel table:

CHANNEL								Value	Function
1	4	5	10-1	10-2	17	4	9		
				1	1		1	See strobe table	Strobe
1	1			2	2	1	2	0-255	Total dimming
	2			3	3	2	3	0-255	fine-tuning
						3	4	0-255	CCT adjustment
						4	5	0-255	Saturation
		1	1	4	4			0-255	R
			2		5			0-255	R fine-tuning
		2	3	5	6			0-255	G
			4		7			0-255	G fine-tuning
		3	5	6	8			0-255	B
			6		9			0-255	B fine-tuning
		4	7		10			0-255	W
			8		11			0-255	W fine-tuning
		5	9		12			0-255	L
			10		13			0-255	L fine-tuning
	3			7	14		6	Refer to CCT channel table	CCT
	4			8	15		7	Refer to the fixed color channel table	Fixed color
				9	16		8	Refer to the dimming mode table	Dimming mode
				10	17		9	Refer to the control channel table	Control channel

CCT TABLE

DMX value	CCT	DMX value	CCT	DMX value	CCT
0-23	No function (4CH 4000K)	44	4400	65	6500
24	2400	45	4500	66	6600
25	2500	46	4600	67	6700
26	2600	47	4700	68	6800
27	2700	48	4800	69	6900
28	2800	49	4900	70	7000
29	2900	50	5000	71	7100
30	3000	51	5100	72	7200
31	3100	52	5200	73	7300
32	3200	53	5300	74	7400

33	3300	54	5400	75	7500
34	3400	55	5500	76	7600
35	3500	56	5600	77	7700
36	3600	57	5700	78	7800
37	3700	58	5800	79	7900
38	3800	59	5900	80	8000
39	3900	60	6000	81	8100
40	4000	61	6100	82	8200
41	4100	62	6200	83	8300
42	4200	63	6300	84	8400
43	4300	64	6400	85-255	8500

23	dark pink	180-201	Forward rotation, fast to slow
24	bright pink	202-207	Stop
25	bright rose	208-229	Reverse, slow to fast
26	special rose pink	230-234	No function
27	vanity fair	235-239	Random color fast (same color for master and slave, different colors for console)
28	magenta	240-244	Random colors (same color for master and slave, different colors for console)
29	dark magenta	245-249	Slow random color (same color for master and slave, different colors for console)
30	rose purple	250-255	No function
31	mauve		

Color chart

DMX value	Color	DMX value	Color
0	No function	32	medium purple
1	pale yellow	33	lavender
2	straw	34	palace blue
3	gold tint	35	dark blue
4	spring yellow	36	medium blue
5	medium yellow	37	deep blue
6	yellow	38	daylight blue
7	deep amber	39	slate blue
8	deep straw	40	light blue
9	loving amber	41	sky blue
10	gold amber	42	pale navy blue
11	orange	43	marine blue
12	deep orange	44	peacock blue
13	dark amber	45	lagoon blue
14	millenium gold	46	medium blue green
15	deep golden amber	47	dark yellow green
16	scarlet	48	primary green
17	primary red	49	fern green
18	bright red	50	moss green
19	medium red	51	dark green
20	fire	52	lime green
21	pink	53	pale green
22	medium pink	54-179	No function

Dimming Mode Table

Dim Modes		123	0.2s	133	2.0s
0-20	Standard	124	0.3s	134	3.0s
21-40	Stage	125	0.4s	135	4.0s
41-60	TV	126	0.5s	136	5.0s
61-80	Architectural	127	0.6s	137	6.0s
81-100	Theatre	128	0.7s	138	7.0s
101-120	Stage 2	129	0.8s	139	8.0s
	Dimmer Delay Time	130	0.9s	140	9.0s
121	0s	131	1.0s	141	10s
122	0.1s	132	1.5s	142 - 255	Idle

Control Channel Table

DMX value	Frequency, curve, built-in program	DMX value	Frequency, curve, built-in program	DMX value	Frequency, curve, built-in program
0-99	No function	127	1170	155	1450
100	900	128	1180	156	1460
101	910	129	1190	157	1470
102	920	130	1200	158	1480
103	930	131	1210	159	1490
104	940	132	1220	160	1500
105	950	133	1230	161	2500
106	960	134	1240	162	4000
107	970	135	1250	163	5000
108	980	136	1260	164	6000
109	990	137	1270	165	10000
110	1000	138	1280	166	15000
111	1010	139	1290	167	20000

112	1020	140	1300	168	25000
113	1030	141	1310	169-200	No function
114	1040	142	1320	201-210	Dimmer Curve Linear
115	1050	143	1330	211-220	Dimmer Curve Square
116	1060	144	1340	221-230	Dimmer Curve Inverse Square
117	1070	145	1350	231-240	Dimmer Curve S-Curve(default)
118	1080	146	1360	241	Internal program 1
119	1090	147	1370	242	Internal program 2
120	1100	148	1380	243	Internal program 3
121	1110	149	1390	244	Internal program 4
122	1120	150	1400	245	Internal program 5
123	1130	151	1410	246	Internal program 6
124	1140	152	1420	247	Internal program 7
125	1150	153	1430	248-255	No function
126	1160	154	1440		

Strobe channel

0-31	LED off	128-159	Pulse flicker speed slow to fast (synchronized for about 7 minutes)
32-63	LED on	160-191	LED on
64-95	Normal strobe speed slow to fast (synchronized for about 7 minutes)	192-223	Random flicker speed slow to fast
96-127	LED on	224-255	LED on

NO DMX table

NO DMX Status	Fixture is powered on without DMX	Fixture is powered on with DMX	DMX Traffic stops	DMX Traffic Starts
Hold Last	Fixture is black until DMX traffic arrives	Use DMX values	Stay on last DMX Values	Use DMX values
Standalone (menu setting fadetime)	Fade into Standalone Settings	Use DMX values	Fade into Standalone Settings	Fade into DMX values
Fade to black	Fixture is black until DMX traffic arrives	Fade into DMX values in 10 seconds	Fade to black in 10 seconds	Fade into DMX values in 10 seconds
0-10V (menu setting fadetime)	Use 0-10V dimmer level, Standalone Color settings	Use DMX values	Use 0-10V dimmer level, Standalone Color settings	Use DMX values

9. Control circuit diagram

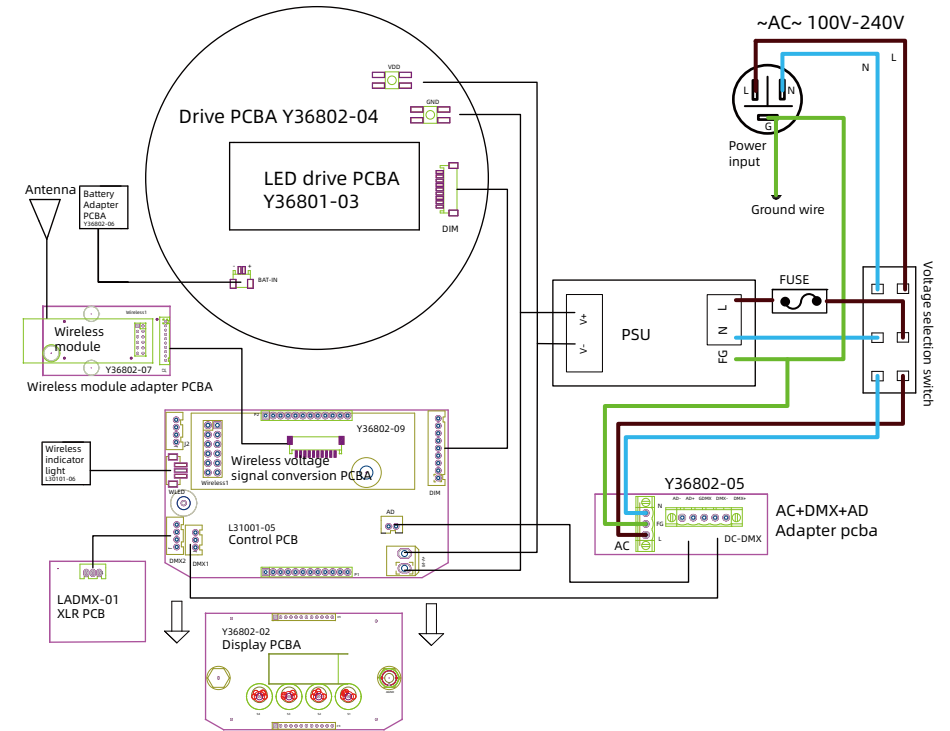

10. Regular maintenance

10.1 Cleaning and maintenance

Lighting fixtures require daily cleaning and maintenance, and their service life largely depends on the operating environment and standards. If you have any questions, please consult our technical engineers for advice. Maintenance and repair work not included in this book should be entrusted to our qualified technical engineers.



Attention! Damage caused by dust, e-liquid, or other reasons, as well as abnormal use, is not covered by the warranty.



Warning !

Before opening any lid, disconnect the power supply. Cleaning optical components requires gentle wiping as the coating surface is prone to scratching. Do not use damaging liquids or hard objects, as they may damage the plastic or coating surface.

- When the lens is cracked or otherwise damaged, it should be replaced in a timely manner;
- When the brightness significantly decreases, the LED may have reached its expiration date and should be replaced in a timely manner;
- When the fixture cannot start, please check if the fixture power fuse is blown. If it is blown, a fuse of the same specification must be used for installation;
- The fixture is equipped with a temperature protection device. When the temperature is too high, the protection device will automatically reduce power.
- When this situation occurs, please check whether the fan is running normally, whether the fan and fan mesh are clogged with dust, identify the fault and repair it before starting the fixture. Please note that only qualified technicians are allowed to carry out maintenance work;
- To maintain smooth movement of the focusing lens, it is recommended to lubricate the guide rail of the focusing lens every three months. Excellent and high-temperature resistant lubricating grease should be used, and excessive grease should not be used as it can easily dirty adjacent components.

Weak light efficiency and uneven light spot	LED aging	Replace
	The optical mirror has accumulated dust or stains	Clean
	The optical mirror is damaged	Replace
Impure color	Weakening of light efficiency	Replace led PCB
	The color filter has accumulated dust or stains	Clean
	The color filter has been demolded or damaged	Replace
 Attention! The above analysis is for abnormal reference only. Non professionals are not allowed to disassemble and repair the machine		

10.2 Fault analysis and handling

Fault description	Analysis	Processing method
No action after power on	Check if the power switch is turned on	Turn on
	Check if the fuse is blown	Replace
	Check if the output of PSU is normal	Detecting voltage
	Check if poor contact in the internal circuit	Reconnect
Uncontrolled lighting fixtures	Check if the DMX signal cable is connected correctly (If there is no signal, the display screen will flash)	Reconnect or replace
	Check if the address code is correct and if the DMX mode of the lighting fixture matches the settings	Reconfirm
	The main control PCB is damaged	Replace
Not bright	LED aging or damage	Replace
	Power PCB malfunction	Check/ Replace
	Loose or poor contact of the circuit	Reconnect
	PSU malfunction	Replace
Automatically turn off or dim the lights	LED aging	Replace
	The temperature control switch is damaged	Replace